

18-4
11

Manual of Instructions
for
Gun Camera

Mark 1

MADE BY
EASTMAN KODAK COMPANY
ROCHESTER, N Y., U. S. A.

Gun Camera—Mark I

GENERAL:

Gun Camera Mark I. has been developed for the purpose of increasing the efficiency of aerial gunnery. By its use a graphic record of the manner in which the student-aviator handles his machine gun in offensive and defensive combat is obtained, his faults discovered and corrections made possible.

This apparatus is mounted in place of the magazine on a Lewis aerial gun equipped with post fore sight and ring rear sights and is operated by simply sighting the gun and pressing the trigger. The camera uses standard moving picture film, takes the pictures automatically as long as the trigger is depressed at the rate of six per second, with an exposure of $\frac{1}{50}$ second, and its magazine holds sufficient film for 97 exposures, this number being the same as that of the cartridges in the Lewis four tier magazine. Each exposure thus represents a single shot of a Lewis gun and the films are marked according to bursts. The magazines are changed in exactly the same manner that the drum magazines of the ordinary gun are replaced, and each gun camera outfit is supplied with a total of three film magazines.

Photographs can be taken perfectly well through the propeller with this camera, thus making its use possible in connection with Lewis aerial guns mounted rigidly in combat machines. Care must be used, however, to prevent oil from getting on the lens and interior mechanism when used with revolving engine.

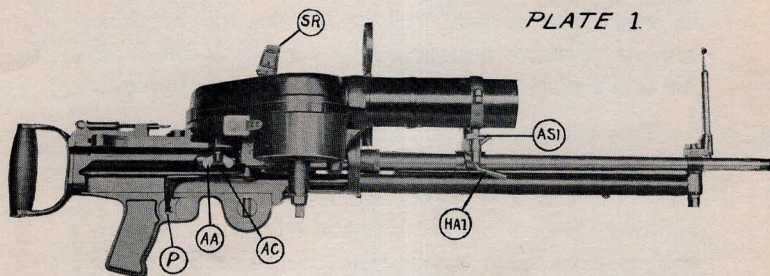

PLATE 1.

Plates 1 and 2 are side views of the camera applied to the Lewis aerial gun, and show the manner in which camera is attached.

To Attach Camera to Gun.

1. Loosen wing nuts "AA", (Plates 1 and 2) and clamping handle "HA" (Plate 2), throw actuating arm "AC" (Plates 1 and 6), outwardly and set camera squarely over magazine post.

2. Tighten clamping handle "HA", adjusting clamp snugly over gun barrel. Catch metal slides

of wing nuts "AA" under adjacent shoulders and tighten wing nuts. Swing actuating arm "AC" inward, pulling it back far enough to allow lock plate to slip around trigger, thus locking "AC" in position.

3. The lock plate may need a small amount of adjustment at screw "P" the first time apparatus is mounted on gun, that it may fit closely to trigger, without binding at any point.

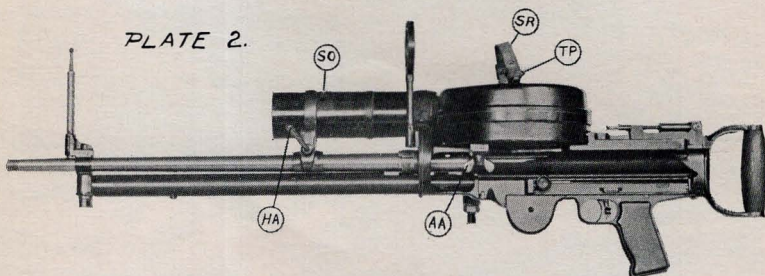

TO CALIBRATE THE SIGHTS:

1. Gun should be equipped with post foresight and ring rear sight and mounted rigidly, preferably in a clamp.

2. Remove film magazine by slipping right hand under strap "S R" (Plate 3), pressing on "T P" with thumb and lifting film magazine up. Remove film pad "F P", (Plate 4) by lifting gently

after pulling out lock stud "S P", (Plate 4) Slip ground glass screen over graticule mounting and hold shutter open by sliding shutter opening attachment "S O" outward.

3. Fasten sighting chart bearing printed crosses, which is packed with every camera, on approximately the same level as line of sights, between 15 and 20 feet from camera. Line gun sights correctly on center of large cross, then adjust camera so that

PLATE 3.

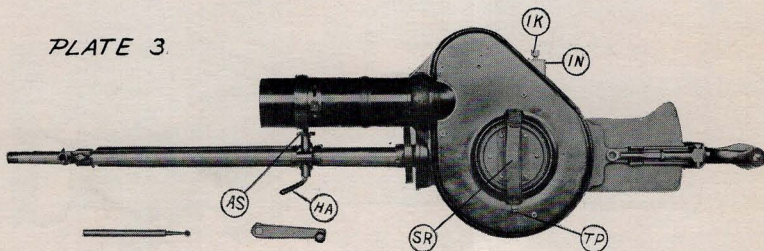

small cross coincides with cross hairs on graticule. Lateral movement of camera is obtained by adjusting screw "AS", (Plate 4), after loosening clamping handle "A H", which is then tightened to act as lock nut after adjustment is made. Vertical adjustment is made by means of screw "A S ¹" (Plates 1 and 6) When this adjustment is complete the line of the lens barrel is parrallel to the line of gun sights. Replace film pad and return shutter opening attachment "S O" so that shutter closes.

TO INSERT FILM :

1. Remove film magazine by slipping right hand under strap "S R", (Plate 3), pressing on "T P" with thumb and lifting film magazine up. Remove film magazine cover by grasping magazine

PLATE 4.

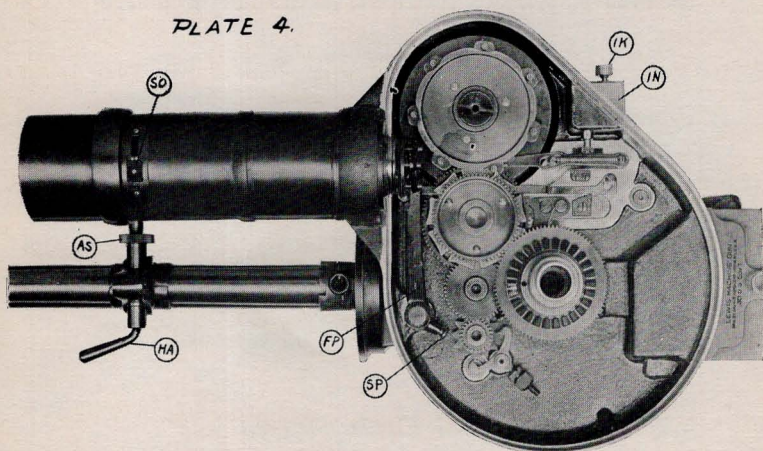

from each side, bottom up, pressing down with a quarter turn on clips "C L" (Plate 5), thus releasing cover. If cover jams it may readily be loosened by inserting finger nail under edge.

2. Plate 5 shows how film is inserted in magazine. Roll is placed on pin "F S", the black paper

being carried around post "G P" through exposure chamber "E C", around post "G P¹" and its end fastened under film clamp on reel "R E" Magazine cover is now replaced, locked by a quarter turn, under pressure, of clips "C L", and reel "R E" turned by means of its projecting lugs "R L" until the hand appears on the black paper. Proceed care-

PLATE 5.

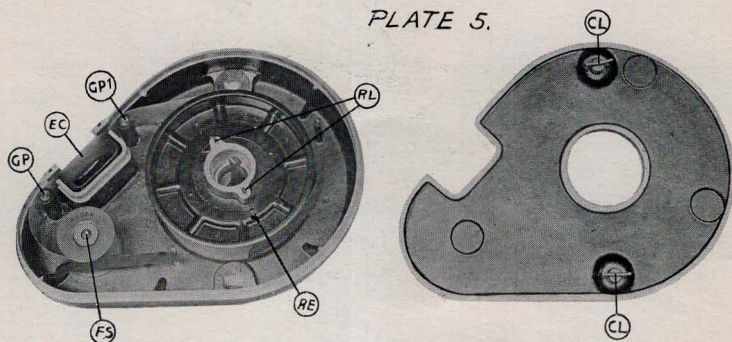

fully until $\frac{1}{2}$ inch of film is exposed in "E C" Magazine is now placed on camera, black paper and film slipping in front of film pad "F P", (Plate 4), care being taken to see catch "T P" (Plate 3) is properly seated.

TO PREPARE FOR EXPOSURE

1. Wind tension spring until tight by means of handle "S H" (Plate 6). Pull trigger until indicator

"I N" (Plate 4) registers one exposure. Now set indicator to zero by turning knob "I K" (Plate 4) Every shot will now be recorded on the film until magazine is emptied.

2. After film has been exhausted, fresh magazine can be put into position in the same manner as

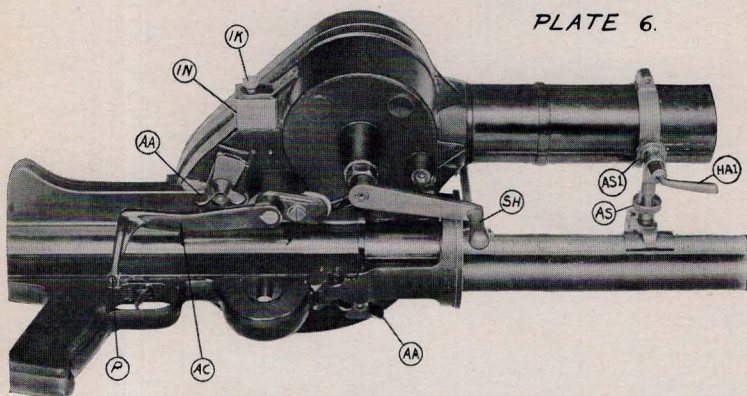

cartridge drums. Care should be taken to assure film slipping between graticule and film pad, that it does not catch. Magazines containing exposed film should be taken to dark room immediately for development or kept in subdued light.