

# ZEISS HISTORICA

Journal of the Zeiss Historica Society • Volume 25 • Number 2 • Fall 2003



## Table of Contents

- 1 President's Letter**
- 2 Zeiss binoculars — The early years** **Jack Kelly**  
*Between 1894 and 1908, Zeiss produced "Feldstechers" in ever-evolving designs*
- 9 Carl Zeiss in the Netherlands** **Nicholas Grossman**  
*The Nedinsco plant at Venlo, set up after World War I, still exists today*
- 12 Alfred Gauthier, Calmbach 1902–2002** **Warren Winter**  
*The makers of the famous Prontor shutters, still thriving after a hundred years*
- 18 Postwar stereo devices from Carl Zeiss Jena** **Bernd Otto**  
*A follow-up to our articles in the last issue on stereo attachments from Zeiss Ikon and Kiev*
- 22 Book review** **John Scott**  
*Alexander Schulz's book on "Contax S: a History of the World's First 35 mm Prism Camera"*
- 11, 17, 24, and inside back cover: Lichtstrahlen**  
*More on the Tessar in 39 mm thread mount, and an advertisement from "Ernst Abbe, Jena," both by Charles Barringer; Ercona advertisement for the Contax S, and some black-and-nickel favorites, from Joseph K. Brown*

The Zeiss Historica Society of America is an educational, non-profit organization dedicated to the exchange of information on the history of the Carl Zeiss optical company and its affiliates, people and products from 1846 to the present.

### Officers

Founder	Thomas Schreiner
President	Lawrence J. Gubas
Past President	Charles Barringer, Jr.
Editor	John T. Scott

Material for the journal can be sent to the Editor at 73 Winsor Place, Glen Ridge, NJ 07028 (e-mail: jscott@viconet.com) or to any Officer. Please send all other correspondence to Zeiss Historica Society, 24 Valley Drive, Randolph, NJ 07869, USA. Annual membership dues: \$35 (USA), \$45 elsewhere. Dues include subscription to Zeiss Historica, airmail postage overseas.

© Zeiss Historica Society, 2003. All rights reserved under Pan American and Universal Copyright Conventions by Zeiss Historica Society. Reproduction without permission is prohibited. Trademarks and names that are the property of Carl Zeiss are used with permission.

Printing by Lightning Press, 615 Route 23, Pompton Plains, NJ 07444.

**Front Cover:** *The shutter-assembly room at the Gauthier plant in Calmbach, 1952. Warren Winter writes on the history of Alfred Gauthier Calmbach on page 12.*



**Back Cover:** *Two views of a 4 × 14 Luxus Feldstecher in Fred Schwartzman's collection. For more on the Zeiss Feldstechers, see the article by Jack Kelly starting on page 2*

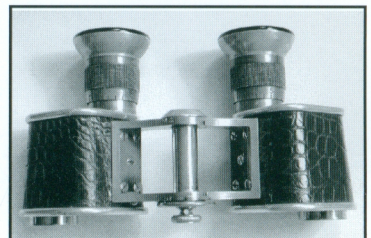
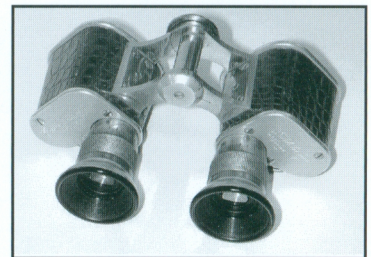

# President's Letter

**Another year is ending** and as I write this letter, I am preparing to meet some of you at our annual meeting at the Fleetwood Museum here in New Jersey. It is a happy prospect to anticipate meeting old friends and new. I have just returned from another trip that my wife has permitted me. It was based on an invitation from Rolf Fricke to speak to the Leica Society about the Zeiss lenses that have appeared on their screw-mount cameras and the contradictions that the subject entails. I took advantage of being in the Midwest to extend my trip to Lubbock, Texas, where I met with one of our newest members, Fritz Jacobsmeier, who is a special member in a particular way. He was an apprentice at Carl Zeiss Jena from 1937 to 1940 and returned there for a short time immediately after the war. He and his wife Marga were kind enough to listen to two days of questions about his days there from this interested party. It was quite informative and will be part of future material that I will be sending to our editor.

I have also just heard from my friend Hans Jürgen Kuc with good news. After many fits and starts, his two books entitled "On the Trail of the Contax," parts I & II, have been translated into English and will be available in late November at about \$55 each. They are already listed on the web page of member Petra Kellers at

[www.camerabooks.com](http://www.camerabooks.com)

Zeiss Historica Society members can now get a 10% discount from the price of these and all other books ordered from Camerabooks. Just write "Zeiss Historica 10% discount" in the message box during checkout.

I have not heard from more than two members with regard to a possible Zeiss Historica meeting in the Frankfurt area of Germany in April or October of 2004. This meeting would be an occasion to see many interesting Zeiss prototypes. If no one is interested in a meeting, then we shall certainly not have one, but if you are interested, please let me know when you receive this issue.

There is also a possibility of a meeting in Germany, in September 2004, of the Binocular Collectors group that met in San Diego last February. It would be in conjunc-

tion with the Wehrtechnische Studiensammlung in Koblenz, where the museum for historical military items is located. Koblenz is in central Germany not far from Cologne (Köln). It would be a very large occasion and well worth a visit from binocular and optical munitions collectors. Contact me for further information since this is in its formative stages.

I have prepared a few articles for a Japanese magazine that have been translated by long-time member Fritz Takeda with regard to the Zeiss Historica Society and in particular the history of the Contax camera. These are not items that will be published in the Journal because we try to make all of our articles original and stand-alone so that you are not getting material that has been published elsewhere. Even the important articles by Bernd Otto are significant updates of material that he had published some years ago. If you have new material or information, please forward it to John Scott, our editor, whose information is on our masthead.

Like most other groups of instrument and camera enthusiasts, our numbers are dwindling. The changes that I made this year with regard to publishing and the additional labor performed by our editor have made this year a positive one financially. However, those of us who perform work are a small group, and any loss there may doom the society. Please make the effort to become a participating member. I was one of the youngest at the founding meetings in 1979 and now I am the chief cook, bottle washer etc. Personal situations may force my move from this location and this job but there is no one to take my place. I am not looking to quit but you know what will happen if that beer truck happens to find me one dark night. We need to be prepared. If you have any interest, please let me know.

You may contact me via the usual means at my email address ([Ingubas@optonline.net](mailto:Ingubas@optonline.net)) or telephone 973-366-2420.

Have a warm winter.



# Zeiss binoculars – The early years

Jack Kelly, Brush Prairie, Washington

---

*Zeiss produced “Feldstechers,” or “field piercers,” from 1894 through 1908, a period that saw continued and detailed evolution of these early binoculars and monoculars.*

---

**1893 Ernst Abbe** secured German Patents numbered 77086 and 76735 in the name of Carl Zeiss Optical Works. These patents covered the design of a new prism binocular that revolutionized the world of field glasses. No longer was the observer limited by a narrow field of view or low magnification. With the new compact design, magnifications of 8, 10 or even 12× were possible and still the field of view was better than the old Galilean design.

Demand grew rapidly. From a modest start of 205 units produced in 1894, more than 125,000 had been turned out by 1907. During the Boer War (1899–1902), British troops found themselves ill equipped for war on the veldt and desperate for Zeiss prism binoculars to spot the enemy. Many officers purchased their own Zeiss binoculars, and some even equipped their troops out of their own pockets.<sup>1</sup> The Zeiss prism binocular established a new

performance standard for field glasses.

Collectors refer to the first series of binoculars from Zeiss as “Feldstechers” (loosely translated from the German as “field piercer”) simply because that is how they are labeled. Figure 1 shows a group of nine Feldstechers plus a monocular of the same family.

All Feldstechers are characterized by a construction method whereby the two telescope tubes are connected by a separately manufactured hinge fastened to each tube with screws (figure 2). Adjusting binocular alignment (collimating) is accomplished by loosening the screws and moving the tubes until the images from each side merge into a single image for the observer. It is an interesting series to collectors, not just because it was the first Zeiss prism binocular but also because of the many variations that exist.

The first offering from Zeiss as described in an 1894 catalog<sup>2</sup> consisted

of six models: three Feldstechers (binoculars) in 4×11, 6×15 and 8×20 size, and three stereo telescopes, 6, 8, and 10× (figure 3). The binoculars are remarkably similar to what we find on the market today, but the stereo telescopes have disappeared and never really made much of an impact except in military applications. The binoculars sold in 1894 for 120, 140 and 160 marks respectively, a very expensive item in its day. In the first abbreviated year of production (the binoculars were introduced part way through the year) 205 units were produced. By 1896 you could purchase monocular versions of the Feldstecher, the 6× stereo telescope had been dropped from the catalog and the 4×11 binocular was replaced with a 4×14 model offering greater light-gathering ability.<sup>3</sup> Production increased to 2775 units in 1896 for a cumulative total of 4251 Feldstechers since the binocular was introduced.<sup>4</sup>

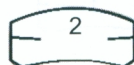

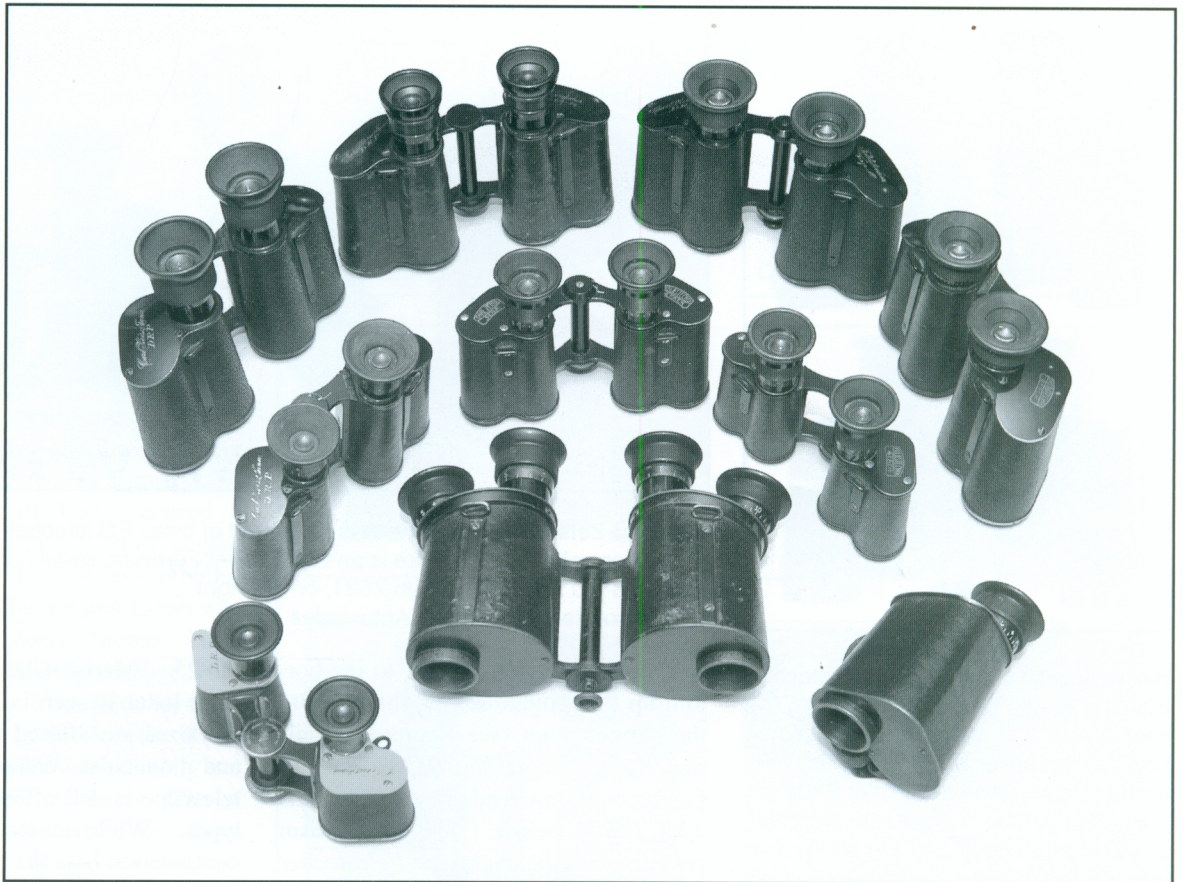

**The Feldstecher family.** Beginning with just three models in 1894, by 1897 nine binoculars and eight monoculars were available. Outer (top) circle, left to right: 5×24, 7½×24, 10×24, 12×24. Inner circle, clockwise from left: 4×11, DF 95, 8×20, 6×18, 12×24 monocular. Center: 5 & 10×24 Marine Revolver. Figure 1

During these first few years of production there were many changes to the design of the Feldstecher (see figure 4 for examples, discussed below). None changed the character of the binocular but, as almost anyone who has worked in a manufacturing business knows, the first production units off the assembly line do not always represent the final product. Improvements are made to facilitate production or reduce manufacturing costs. Design weaknesses are corrected. Changes are made to improve durability based upon initial feedback from users, and additional models are developed from the initial design. Add to this that Zeiss was dealing with brand-new technology and producing products in very limited quantities using skilled craftsmen, and you can appreciate the variations that occurred in the first few years of binocular manufacturing. Some changes were certainly enhancements or improvements but

there are some that I cannot explain in any way except that they were the result of individual decisions by craftsmen or possibly customers.

One example from my collection highlights this. Two 6×18 binoculars only 247 numbers apart are both marked Carl Zeiss. Serial number 5378 has aluminum top-prism cover plates and brass on the bottom. Serial number 5625 has exactly the opposite with brass on top and aluminum on the bottom. Another example, from Fred Schwartzman's collection, consists of two 6×15 binoculars, both marked C. Zeiss and functionally identical. Serial number 668 has brass bottom-prism cover plates and aluminum top cover plates; serial number 1676 has brass plates on top and bottom. On the other hand serial number 1676 has a body that is 3 mm taller than number 668, and that certainly cannot be attributed to anything but a planned design change.

Most of these changes were permanent, representing progression in design, manufacturing processes or style. Examples of these permanent changes include the steady improvement in eyecup design starting with a 100% vulcanite eyecup followed by one that is two thirds vulcanite, one third brass, and finally an essentially all brass ocular assembly with a small vulcanite eye ring. Another is the move away from the script logo to the stylized lens logo with block lettering. On the other hand, the method of engraving the binoculars seems to vary year to year. The earliest glasses used a cut engraving style. Later the engraving was filled with a silver-bismuth alloy. Later yet, cut engraving re-appears.

Earliest examples were labeled in script with the words C. Zeiss, Jena on the left prism cover, D.R.P. on the right cover and the magnification on the center hinge cover. The center hinge cover

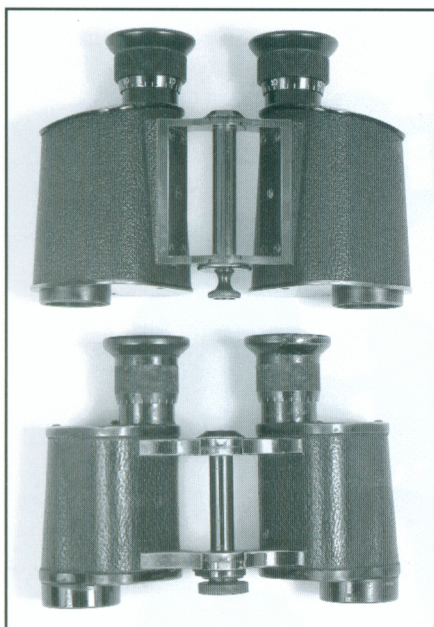

**Hinge design.** Top: 10×24 Feldstecher; Bottom: 8×24 Telact from 1908. The Feldstecher has a separately machined hinge assembly screwed to the two telescope bodies, while the newer 8×24 utilizes a hinge cast integral with the body. In all cases, hinges and lug straps that are attached to the body with screws characterize the Feldstecher series of binoculars. Figure 2

is flat and engraved with a number to indicate the magnification of the binocular. In the case of the earliest 4×11 in my collection, the strap lugs, made of cast brass, are quite small, and have a small round hole to take a cord-style strap or snap. This same cast strap lug is depicted in catalog illustrations of the early 6×15 binocular but I have not seen one in real life. We have neither photographs nor samples of 8× binoculars with this strap lug, but it is my opinion that the same style was used on all of the first three earliest models.

**Improving the design**

In 1896 the 4×11 Feldstecher was replaced with a 4×15 model.<sup>5</sup> By 1897, catalog offerings had been expanded to include 5×25, 7½×25, 10×25, and 12×25 binoculars and monoculars.<sup>6</sup> These models incorporated several improvements to the original Feldstecher design. While retaining the smooth one-piece eyecups noted above, focus-



**The first Zeiss binocular models** consisted of three Feldstecher models and three Relief Fernrohre. Shown here is an 8×20 Relief Fernrohr, serial number 8, on the left and an 8×20 Feldstecher, s/n 7521, on the right. (Photo courtesy of Thomas Antoniadis.) Figure 3

ing hash marks were added to the bottom lip to facilitate setting the focus to the correct point (see figure 4). Additionally, the engraving on the top left prism cover now reads *Carl Zeiss, Jena* with *D.R.P.* below. The right prism cover carries the engraving *Feldstecher* with *Vergr.=8* below. All marking is in script. The flat top hinge cover is blank. 1899 offers the introduction of the new 6×18 glass to replace the 6×15 and the new and unique revolving ocular 5× and

10×25 “Marine-Glas m. Revolver.” (The latter is seen in figure 1, center). All sizes are offered in both binocular and monocular versions, and the stereo telescope is still offered in 8× and 10× types. While most of the binoculars continued to bear the Feldstecher marking, the new 5× and 7½× glasses were labeled “Jagdglas” (hunting glass) because of the extra light-gathering power of the 25 mm objective lens. In English catalogs these were also

**Evolution of eyecup and lug strap design.**

Clockwise from bottom right: the first eyecups were smooth and devoid of any markings to aid in setting the focus (4×11, s/n 575). By approximately 1896 hash marks were added to the eyecup and a reference line to the ocular tube (6×18 s/n 775). Later, the ocular design was changed to incorporate a machined brass diopter ring with the top two thirds of the eyecup, including the knurled focusing knob, made of vulcanite (8×20 s/n 8655).

The introduction of the larger diameter ocular tube assembly seems to coincide with the introduction of the cell logo and Roman lettering sometime after 1904, and this included a complete redesign of the focusing mechanism now made completely of brass and topped by a small vulcanite eyecup (6×18 s/n 8462). These pictures also show the various strap lug designs from the earliest cast brass examples followed by the long and then the short strap. Figure 4

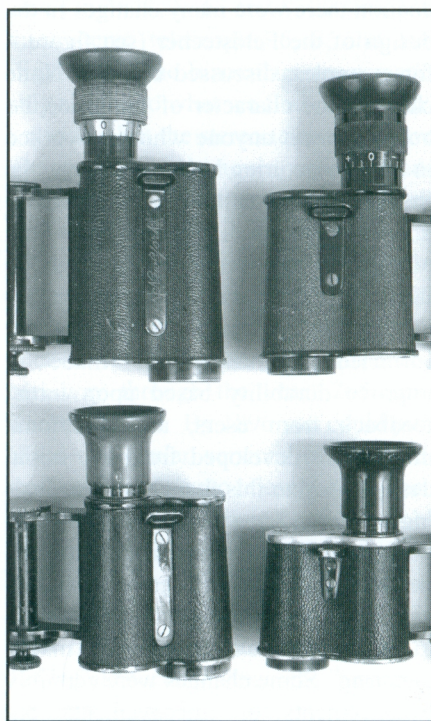

referred to as “Night Marine Glasses” and the 10 and 12× glasses as “Day Marine Glasses,” but I have never seen a binocular actually marked that way.<sup>7</sup>

By the end of 1899 Zeiss had manufactured 21,370 Feldstechers and production reached 8000–9000 units per year, where it remained until 1904 when it jumped to 13,278 and then 17,698 in 1905.

In about this same time frame, additional manufacturing facilities and manufacturing arrangements were established; several of the resulting instruments are shown in figure 5. E. Krauss and Co. of Paris secured a license from Zeiss in 1897 and labeled their binoculars the “Stereo-Jumelle-Zeiss.” By 1898 Bausch and Lomb was manufacturing “Zeiss Stereo Field Glasses” in the US under license from Zeiss. Binoculars from both of these concerns closely resembled the Zeiss Feldstecher design but are certainly not identical to the Zeiss products. One of the agreements included in the Zeiss B&L contract required a mutual exchange of technology. Zeiss would provide B&L with optical design technology and B&L, in turn, provided Zeiss with much needed mass-production technology. Zeiss Feldstecher glasses have been found carrying markings from St. Petersburg, but while Zeiss also opened manufacturing facilities in London and Vienna in this time frame I have not personally seen or heard of an early Feldstecher with a London or Vienna label.

Sometime in the first years of the twentieth century several design changes found their way into production. These included:

- ◆ The smooth, flat top center hinge cover is replaced by a beveled cone design with interpupillary hash marks and the number 60 and 70 designating the user’s interpupillary eye spacing in mm. (figure 6c)
- ◆ The knurled vulcanite eyecup is replaced with a machined brass barrel capped with a vulcanite eyering. Markings on the ocular have been standardized with hash

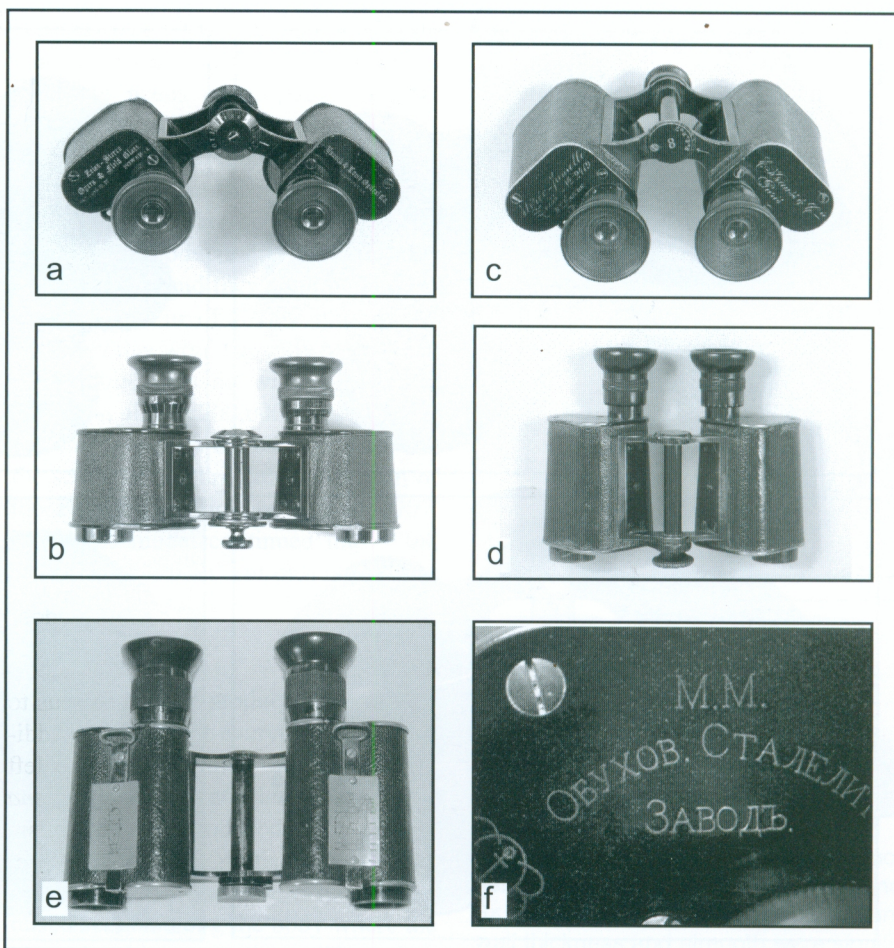

“Zeiss Feldstechers” from other manufacturers. Parts a and b: by Bausch & Lomb in the US; parts c and d: by Krauss in France; parts e and f: by Zeiss in St Petersburg, Russia. (Russian Feldstecher photos from Fred Schwartzman.) Figure 5

marks and numbers to indicate the focus adjustment.

- ◆ In 1904 Zeiss registered a new logo, the now familiar lens doublet with Carl Zeiss above and Jena in the lower element. The early script logo was replaced with block lettering and the new lens logo sometime after 1904. (figure 7)

Variations still exist. Later models of the Feldstechers are found with both brass and aluminum top prism covers. Strap lugs are found in aluminum and brass, both short and long. Cut engraving returns again.

**Continuing development**

The 1904 Zeiss catalogs show no change in the models offered but the specifications have changed. Field of

view has increased for the 4, 6, 8 10 and 12× models. This was accomplished by redesigning the eyepiece and incorporating larger diameter field and eye lenses. To accommodate the larger lenses in the 4, 6 and 8× models, the body of the ocular increased in diameter by 2.5 mm (0.1 inch) to 20.3 mm (0.8 inch). The larger 10 and 12× glasses accommodated the change without an increase to the ocular tube. At the same time, the objective diameter for the 5, 5 and 10, 7½, 10 and 12× models is given as 24 mm rather than 25 mm, probably to reflect the actual clear diameter of the lens rather than a change in design. The price of the 4× glass has decreased from 120 marks in 1894 to 110 marks in 1904.<sup>7</sup> The 6× and 8× have also decreased to 120 and 130 marks from 140 and 160. There are no changes to models or prices shown in the 1906 cat-

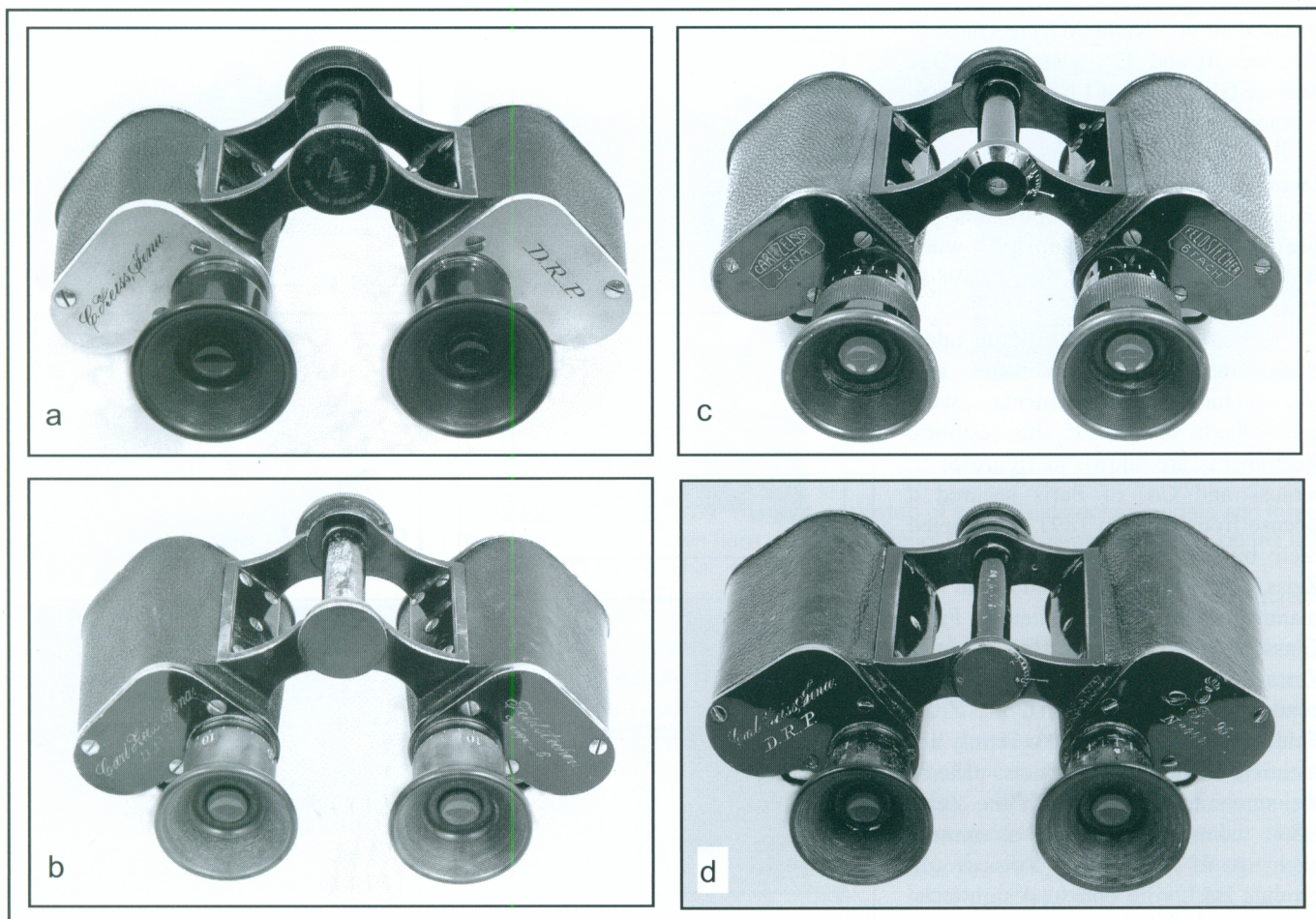

**Variations in the center hinge cover.** The very first center hinge cover (part a) was flat, large (20.4 mm diameter) and marked with the magnification of the binocular. By 1896 (part b) the size was reduced (19.7 mm diameter) and the magnification marking was gone, but it remained flat. Sometime between 1898 and 1899 a new “beveled” hinge cover appeared (part c) with markings to assist in setting the interpupillary distance for each user. From their first introduction, the military Feldstechers (part d) used a slightly beveled hinge cover with interpupillary markings and a setscrew to prevent accidental loosening of the cover. Figure 6

alog,<sup>8</sup> but sometime after 1904 the size of the 6× and 8× bodies was increased, resulting in a much larger feel, similar to modern binoculars. The 4× most likely increased as well but I have been unable to find one to measure. There is no apparent reason for the change since the ocular tube assembly and prisms remain unchanged and can be interchanged between large and small body binoculars. My speculation is that the change was made to strengthen the binocular, because the original body was extremely thin in the area where the ocular screws into the body, and field failures must have been significant. The weight of the 6× binocular increased by 84 g (3 oz) and the 8× by 51 g (1.8 oz) as a result of this change (figure 8).

The year 1907 was critical for Zeiss. The 1903 B&L catalog listed the B&L

Zeiss Stereo Binoculars for \$63 and the B&L Prism Binocular for \$45. Referring to the B&L Prism Binocular, the catalog states that *“These Binoculars are constructed on the same principle as the Bausch & Lomb–Zeiss STEREO Binoculars, except that the objective lenses are no farther apart than the eye-pieces are, hence the same degree of stereo-scopic relief is not obtained in the image. Next to STEREO, however, they are at least equal to the best to be found in the market and are put forward to meet the demand for a thoroughly reliable and high class prism binocular at a less price than that which the superiority of the STEREO commands.”*

**Patent protection**

B&L was able to charge a 37% premium for the Zeiss patent-protected

design, even though the fifteen-year patent-protection period was about to expire. Competition was everywhere. The immense popularity of the prism binocular had brought just about every optical manufacturer into the market. Goerz, Hensoldt, Voigtländer, Busch, Leitz, Ross, Aitchison, Dolland, B&L, Gundlach Manhattan, Warner and Swasey of telescope fame, Krauss, Huett and many others were all in direct competition for the binocular customer. The essence of the Zeiss patent was “increased stereo effect” caused by the wider spaced objective lenses that in effect increased the spacing of the eyes and enhanced depth perception. Zeiss had ardently protected its patent rights over the years, forcing violators to change their design, pay a licensing fee or go out of business while the Zeiss

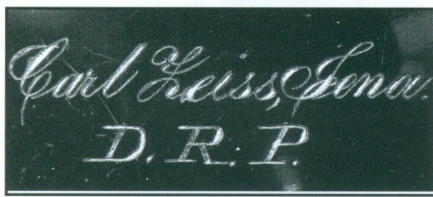
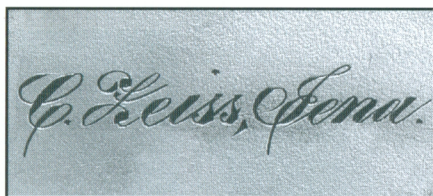

**The Zeiss logo.** Like most aspects of the Feldstecher, the Zeiss logo changed with time. The very earliest Feldstechers, produced from 1894 through approximately 1895, were marked with a cursive script "C. Zeiss" (top photo). From approximately 1896 through 1905 the logo retained its script form but used the full Carl Zeiss name (center photo). The modern version of the Zeiss lens-cell logo that remained in use by Zeiss Jena until 1991 first appeared on Feldstechers sometime after 1904 (bottom photo). Figure 7

patent was in effect (figure 9). All competitors were forced to design binoculars with the distance between the centers of the objective lenses spaced no further apart than the centers of the ocular lenses, while Zeiss continued to extol the virtues of enhanced stereo effect achieved with wider spaced objectives.

By 1908 everyone could make "stereo" binoculars, and they did. Zeiss's response to this was a whole new series of binoculars introduced in 1907 for the 1908 model year. For the first time, body and hinge were cast in one piece (see figure 2). Rigidity, brightness, and dust resistance were the new themes for the catalog writers. Zeiss had entered a new world and fully understood that the future success of

their binocular business depended upon quality, features, and special models to meet the needs of diverse users. By 1914 their catalog had expanded to 22 different binocular models plus an additional ten monocular models. On the eve of World War I cumulative Zeiss binocular production had reached 432,900 units and they were being produced at the rate of 50,000 units a year, a number that would quickly be eclipsed by wartime demand when production peaked at almost 200,000 units in 1918. But that is a different story, far beyond the scope of this article. Production of the Feldstecher did not end in 1907. The 8×20 model continued into 1908, when the "8×20 alt" (or old) model was listed in the catalog for 130 marks.<sup>9</sup>

**The monocular**

Monoculars were produced in low volume for just about every version of the Feldstecher beginning in 1896. It is important to separate the true monocular from those produced from a damaged binocular. A factory-produced monocular will not have a rectangular raised section along the body where the binocular hinge mounts. The prism cover is marked with both the Zeiss logo as well as the model identification, and tiny serial numbers are stamped into the top cover adjacent to the ocular tube (see figure 10). The most common monocular produced was the 8×20 and the highest serial number in our database is 1571. Obviously, while not typically sought out by the binocular collector, these are quite rare.

**Military Feldstechers**

From the beginning, the military saw the benefits of the new binocular. Compact size, increased magnification and increased field of view, coupled with light weight and enhanced depth perception, made the Feldstecher almost irresistible to the soldier or sailor. Almost immediately, officers, who purchased their own binoculars, opted for the Feldstecher. The German Army quickly specified military versions, and the ODF 95 (6×18) and DF 95 (8×20) were offered to the war department for tests in 1896. Later, following design

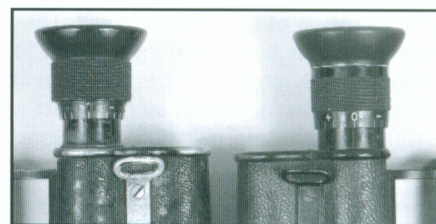

**Increased body size.** With the introduction of a larger body for the 4×, 6×, and 8× binoculars late in the production run, wall thickness and strength were significantly increased. These thick-walled binoculars feel significantly larger in the hand and were a precursor to the larger body sizes introduced in 1908. Top photo: a disassembled, thick-walled 6×, below, compared with an earlier thin-walled body. Bottom photo: the larger ocular tube on the right. Figure 8

changes that appear to coincide with the introduction of the larger field of view, the models were given new designations of DF 6X and DF 8X. There appears to be very little difference between the 6× civilian and military models with the exception of the addition of an interocular adjustment scale on the center hinge cover. However, the DF 95 and DF 8X have a distinctive "sloped shoulder" shape to the top prism covers that was carried over into the new civilian 5, 7½, 10 and 12× models introduced in 1896 (See figure 11).

The Stereo-Telescope (Relief Fernrohr) enhanced the important military characteristics of the Feldstecher and provided the added benefit of enabling a

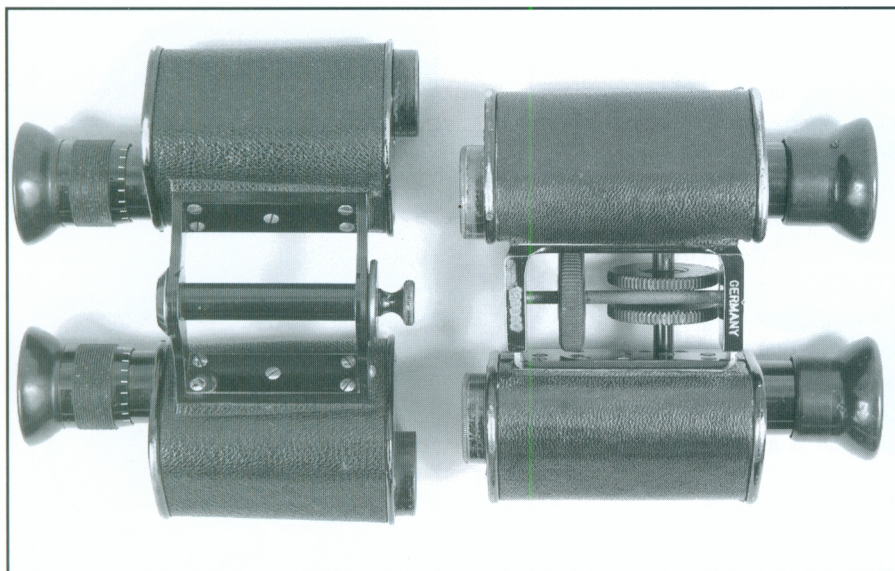

**The essence of the Zeiss patent.** The placement of the objectives so that they are spaced further apart than the oculars (and the viewer's eyes) increases the stereoscopic effect, and was the basis for the patent granted to Zeiss in 1893. Zeiss referred to this increased stereo effect as "plasticity." Shown here are contemporary 8x20 models from Zeiss (left) and Goerz (right). Figure 9



**The monocular.** Beginning in 1896 Zeiss offered monocular versions of their Feldstecher. Shown here is the 12x model. Note (inset) the tiny serial number 694 stamped near the eyepiece. Figure 10

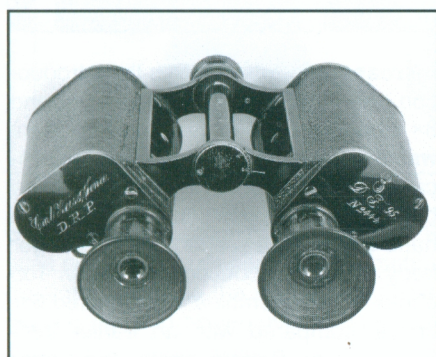

**The military Feldstechers.** "DF," standing for "Doppel-Fernrohr" (twin telescope), was used to designate binoculars designed for military service, and this DF95 was based closely on the early Feldstecher design. The model designation was later changed to DF8X, possibly related to the introduction of the new wider-field ocular. Figure 11

soldier to observe the battle from a trench or from behind a tree without being seen. Artillery observers were able to judge the point of explosion relative to the target with much greater accuracy due to the great depth perception of the Stereo-Telescope. The subject of military applications of the early Feldstecher and Stereo Telescope obviously needs more work.

In conclusion, Zeiss opened the door for the modern binocular with its first Feldstechers. The initial models went through many changes as designs were developed, manufacturing processes refined, and user applications better understood. The binocular that emerged from this birthing process in 1908 set the standard for binocular production for most of the twentieth century.

Understanding the evolution of the Feldstecher series has been and will continue to be a matter of slow and steady detective work. Little has been found in the way of Zeiss factory records from this era, and that makes the search for history all the more challenging. It is to be hoped that other ZHS members will add their knowledge to what I have presented here and share it with others with an interest in the field of binocular history.

Finally, I want to thank Thomas Antoniadis, Hans Seeger, Fred Schwartzman and Larry Gubas for their generous sharing of information and their critical support during the preparation of this article.

For a fascinating look at the evolution of binoculars after 1907 get a copy of Hans Seeger's two books.<sup>10,11</sup> They are written in German but contain a wealth of information about this fascinating field.

**References**

1. William Reid, "Binoculars in the Army," National Army Museum, London, 1982-85.
2. Zeiss Prospectus T./Z.1, October 1894.
3. Zeiss Prospectus No. 2, April 1896.
4. Zeiss Archives, document no. 17095: *Zusammenstellung der Produktionszahlen.*
5. Zeiss Prospectus Third Edition, T.1, March 1897.
6. Zeiss Prospectus Fifth Edition, T. 19, May 1899.
7. Zeiss Catalog T.57, June 1904.
8. Zeiss Catalog T. 57, July 1906.
9. Zeiss Catalog T. 74, August 1907.
10. Seeger, Hans T., "Feldstecher: Ferngläser im Wandel der Zeit," Borken, 1987.
11. Seeger, Hans T., "Militärische Ferngläser und Fernrohre," Hamburg, 1996. □

# Carl Zeiss in the Netherlands

Nicholas Grossman, Rockville, Maryland

---

*In the difficult years after World War I, Carl Zeiss, Jena set up a plant in Venlo to avoid some of the penalties imposed on Germany. The company, "Nedinsco," still exists today.*

---

On 11 November 1918 the guns fell silent all over Europe. Armistice, the agreement to end the fighting, was accepted by both sides in the conflict. By 23 June 1919 the German government gave up its futile attempts to modify the harsh terms offered and signed the Treaty of Versailles. Germany was forced to agree to heavy war reparations, to surrender some of its manufacturing equipment, and to suffer restrictions on rearmament. These restrictions had a profound effect on the Carl Zeiss Stiftung.

The Stiftung management devised a two-pronged solution:

- ◆ Develop and market new products, unrelated to the military. Among these newly marketed products were the automobile electric headlights, introduced in 1921; the first Planetarium installed in the Munich Museum in 1923; and the successful formation of Zeiss Ikon A.G. in 1926.

"know-how" and providing badly needed income. This was not the first time that Zeiss had established manufacturing facilities outside Germany. For various specific reasons in the

early 1900s Zeiss operated plants in London, England; in Vienna, Austria; in Győr, Hungary, and in St Petersburg, Russia.

## Nedinsco established

The Nederlandsche Instrumenten Compagnie (in English, Dutch Instrument Company), known by its initial letter groups as "Nedinsco," was formed through a public Notary Act registered in The Hague (*s' Gravenhage*) on 12 January 1921. Their factory was built in the city of Venlo, in the Netherlands, near the Dutch-German border, and it still exists today. (Venlo lies about 40 km, or 25 miles, west of Düsseldorf, Germany.)

The official justification for Nedinsco's formation was given as the termination of optical-instrument production by the Dutch East India Company (Hollandsch Indische Compagnie). In reality the firm was a wholly owned subsidiary of Carl Zeiss, Jena, and was located in the Netherlands because Germany was not allowed to manufacture military-related products after the War. The location in the Netherlands also circumvent-

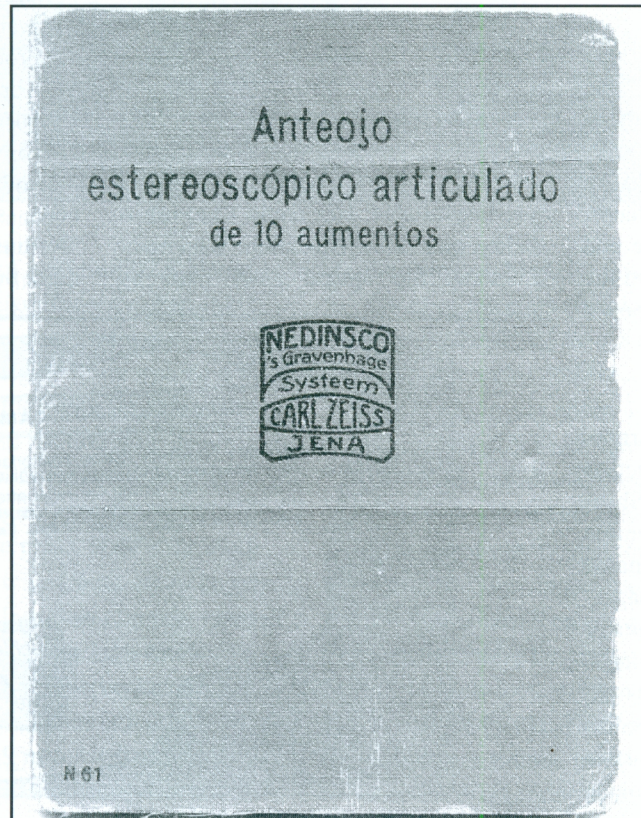

**Cover of an Instruction Book** for binoculars supplied by Nedinsco to the Argentine armed forces. Note that the logo includes the location "s'Gravenhage" (or "The Hague") as part of the trademark. Figure 1



The trademark on a binocular gunsight now carries the name of the city of manufacture, Venlo, in place of s' Gravenhage. Figure 2

The current letterhead of the company includes the "Venlo" version of the trademark but omits the word "System." Figure 3



ed the requirement, under the Treaty of Versailles, that Germany turn over some of its production capability to the Allied Powers. Another important factor was that Nedinsco could fabricate and export their optical products around the world, without the constraints imposed on Germany.

**Trademarks**

Nedinsco used two different trademarks. Figure 1 shows the Instruction Booklet (in Spanish) for Military Shear Binoculars supplied to the Argentine armed forces; note that below the name Nedinsco is written "s' Gravenhage." Other instruments carried a trademark with "Venlo" written below the company name, as on the binocular gunsight illustrated in figure 2. Note that Nedinsco never had any fabricating facility in the city of s' Gravenhage, yet this name was used on some of the trademarks.

I contacted the Nedinsco Company a few years ago, to obtain product information and to ask about the two different trademarks. Their representative

responded that the Venlo plant was seriously damaged in 1944, and that documentation on this question was therefore unavailable. Nor could I get information on a related question: Who manufactured the optical glass used by

Nedinsco? Was it made in Germany or in the Netherlands?

Note that the currently used letterhead, shown in figure 3, keeps the "Nedinsco/Venlo" version of the trademark but omits the word "System." □



As a postscript to the accompanying article by Nicholas Grossman, Larry Gubas found this "Nedinsco Primo" offered for sale in a Canadian auction. It seems to be a relative of the Contina Ia. In the text it is described as a "Nedinsco-Venlo" camera, as in the trademarks illustrated above. But where is the rangefinder?

*Lichtstrahl....*

## More on the Tessar in 39 mm thread mount

Charles Barringer, Haddonfield, New Jersey



I was very proud of my photo of a 50 mm f/2.8 Tessar cutaway lens on the cover of *Zeiss Historica*, Fall 2002, both as a historical document and as a photograph, despite nagging doubt about the lens's origin. There was no way to know for sure (having only half the lens); the thread mount did not quite measure 42 mm, and the cosmetic details were not completely consistent with a known 50 mm f/3.5 Tessar from CZJ; close but no cigar. I should have listened to my inner voice before going to press. Here's the story.

On seeing my cover photo, a wise friend, more deeply steeped in general photographic lore than I, gently pointed out that the Tessar shown was, in fact, a little-known version of the famous lens produced in Oberkochen in the mid-fifties. A small quantity in two number batches was fitted into a focusing mount with 39 mm × 1.0 mm threads. Other details, while confirming that the designers in Jena and Oberkochen were aiming to please the same market, are systematically different.

Confirming this, my wise friend also showed me an undated brochure from Carl Braun, Nürnberg discussing

the "famous BRAUN Paxette programme." There is the Tessar in question (in fact, a prototype) prominently and proudly displayed on a Super Paxette body, produced in 1956 (according to McKeown's guide.)

This discovery opens a fascinating new chapter in the "Zeiss lenses in Leica screwmount (LTM)" discussion. Thanks to considerable research and new raw data, there is no longer any doubt that Zeiss Jena made lenses in LTM. But I had not been aware that that Zeiss Oberkochen did also, or at least in a 39mm thread mount looking very similar to it.

Let me hasten to point out that while the thread is 39 mm × 1.0 mm, the flange distance is unique to Braun, longer by at least 10 mm than the classic LTM. So you cannot couple this lens successfully on your camera with the classic lens mount, or even get a focused image without an adapter. The history of the intersection of Zeiss and Leitz does not repeat itself, but comes pretty close.

Finally the doubts I had previously had about the true identity of the cutaway lens now square with its provenance and I can sleep again with a clear conscience. □

# Alfred Gauthier

## Calmbach 1902 – 2002

Warren Winter, Mt. Kisco, New York

---

*Last year saw the centennial of Alfred Gauthier Calmbach, famous for its shutters, part of the Carl Zeiss consortium and now known as Prontor – Calmbach.*

---

**It is hard to believe** that it was just over 100 years ago that the art of camera manufacturing was advanced by the products of Alfred Gauthier, a name that has graced countless shutters all these years. As we all know, there has been competition. The firm of Friedrich Deckel with their Compur products was a clear leader for many years, and, more recently, Copal from Japan has made a niche in the shutter market. But in the waning years of the leaf shutter, it was Alfred Gauthier Calmbach (or AGC) and the Prontor shutter that would survive as the “German standard” in leaf-shutter manufacturing.

For those who know the design and use of leaf shutters, it is no surprise that the Prontor Werk (AGC’s current Zeiss name) would win out over its cousin — which was also controlled by Zeiss. Prontor shutters were always simpler and typically less prone to failure than Compur shutters. While Compurs always had that fine *Deutsche qualität* look and feel, historically they were more expensive and in the end fell to the cost cutting and consolidation that the photographic industry has existed in for some time.

Many portions of the following narrative are excerpts from *50 Jahre Alfred Gauthier GmbH*, published in 1952 by the manufacturing concern on its 50th anniversary, and given to its friends and

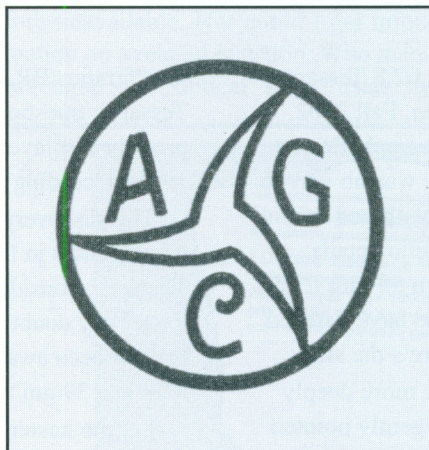

employees as a memento marking that occasion. Other contributors include Larry Gubas, ZHS President, and information provided by Gerd Winter of Prontor – Calmbach.

### **Alfred Gauthier and his family**

As we can tell from Gauthier’s surname, his paternal ancestors were from

France. Although he was born in Germany (in 1871, at Pforzheim) his name should be pronounced in the French style (“gaw t’yay”) rather than as German (“gow teer”). Pforzheim is a city 15 km northeast of the smaller community of Calmbach in Germany. Calmbach has been the home of the Alfred Gauthier plant since the beginning and remains the home of the present Prontor-Werk.

Alfred Gauthier’s grandfather, Napoleon Gauthier, was a jewel merchant from the French Jura who settled in Pforzheim and continued to supply precious stones to the local jewelry trade. Alfred’s father, Hermann Gauthier (born 1844), was an educated mechanical engineer who studied under Phillip Reis, an inventor. Hermann and his younger brother continued to supply products to the jewelry trade, and they expanded to manufacturing materials under the name of Gauthier Brothers (*Geb Brüder Gauthier*). Both Alfred and his younger brother, Gustav, learned the jewelry manufacturing trade in the family business. They both received further education in Geneva and finished training in Paris, where they worked in the

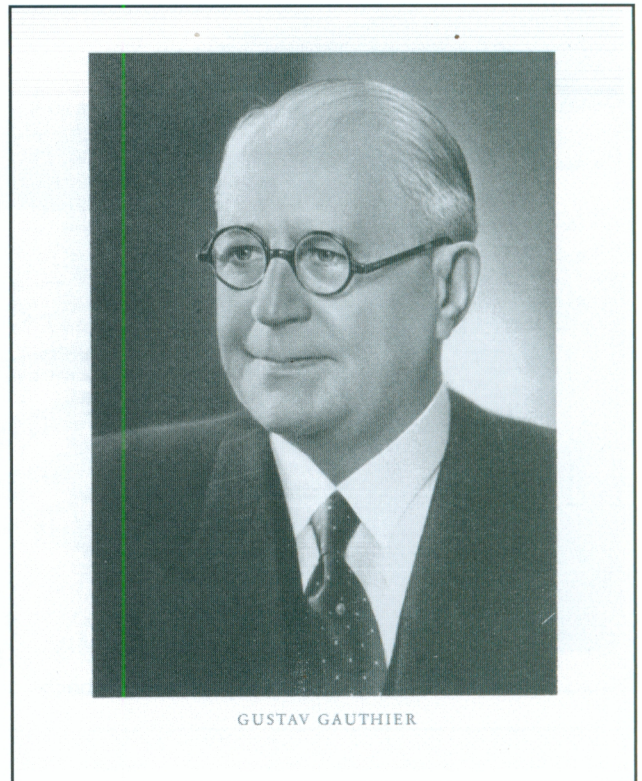

photo-apparatus industry. By 1896, Alfred Gauthier, *Mecanicien Constructeur, Appareils Photographiques* was founded in Paris. Both brothers had the “photography” bug and proceeded to produce fine cameras and other apparatus. It appears that at this time Alfred returned to Pforzheim, where he utilized his father’s workshop to produce parts for the camera business in Paris. Gustav continued to run the Paris operation.

With the growth in the business, and the need for more space, Alfred moved the manufacturing operation from Pforzheim to Calmbach in 1901, and on 21 April 1902 he commenced business as Alfred Gauthier *Feinmechanische Werkstätten Calmbach*, where all operations were consolidated. Calmbach proved to be an excellent location, being the center of a primarily agrarian community in the Black Forest. There was ample affordable labor and space to grow.

#### Alfred Gauthier GmbH

By 1910 Alfred incorporated his concern as Alfred Gauthier GmbH, with a capitalization of 250,000 RM. During the First World War the company

“geared” up for military work. After the war, the business branched out into lathe and other specialized equipment manufacturing, in addition to returning to photographic manufacturing, which helped support the enterprise during the rapid inflation period in Germany. Although lathe and stamping equipment were manufactured for internal use, AGC would now become a leading manufacturer of machine tools. Alfred remained active in the business until 1931, after which Gustav continued to shepherd their creation. 1931 also saw Carl Zeiss invest in Alfred Gauthier GmbH, with an 80% stake in the business. It is no wonder that Alfred retired.

Gustav remained in command during some of the darkest hours of the company. Business was severely hindered during the great depression. Employment dropped to its lowest levels in 1934, until once again, wartime saw civilian work cease and government-dictated manufacturing begin. Men went to war, and many women replaced them in the factory. After the second war, reparations resulted in many of the key pieces of manufacturing equipment being taken away in payment.

Alfred Gauthier died on 7 September 1950. Gustav continued to be active for several more years, through the Golden Jubilee of AGC-Prontor in 1952, and he passed away on 16 January 1963. With a minority ownership still in the family, Gustav’s daughter, Frau Suzanne Rommel, continued on the Prontor Board until 1970. Key business areas continued to be shutters, machinist tooling and stamping equipment.

By the mid 1950s the incursion of Copal and the growth of focal-plane shutters were beginning to carve out their niche in the camera industry. Zeiss and others continued to develop their leaf-shutter stable of cameras, in spite of the now present paradigm shift. This slowness to change had to do both with the greater stake Zeiss now took in Compur-Werke and with the overall success of the Contaflex line as one of the most popular amateur camera lines in the world. Voigtländer, which delivered finely finished leaf-shutter cameras including its Bessamatic, Prominent, Vitessa (ah yes, the Vitessa) and economic Vito (-matic) brands, had yet to make anything but a leaf-shutter product. Heinz Küppenbender of Zeiss had

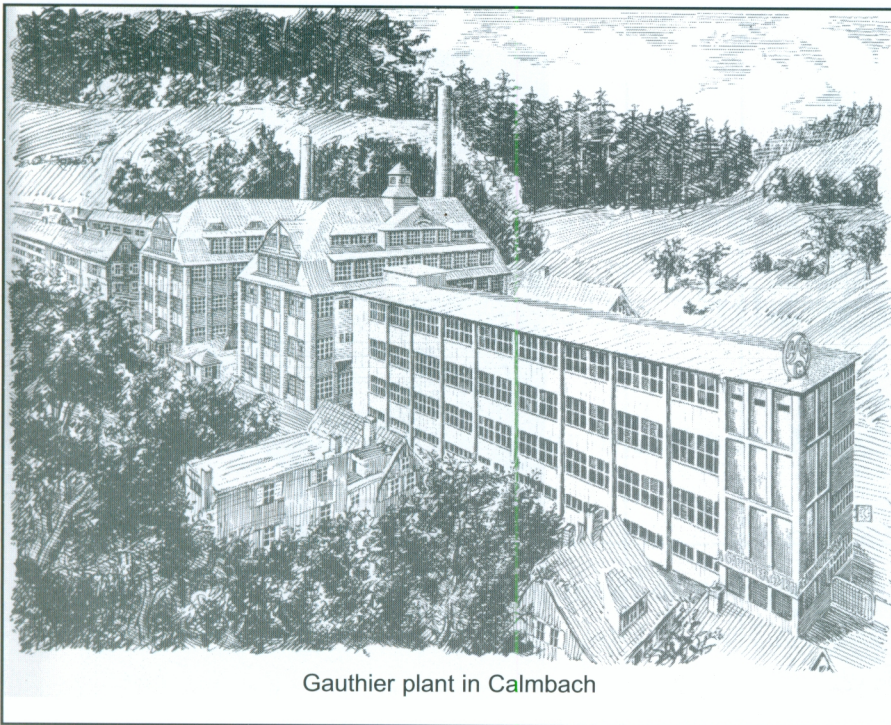

Gauthier plant in Calmbach

been a senior supervisory board member of Voigtländer from the mid 1950s, and the Zeiss interests were well served by Voigtländer, keeping Prontor and Compur busy delivering the best in leaf shutters.

With the impending replacement of the Contax by the Contarex in 1960, Zeiss finally took the step to join the universe of modern single-lens reflexes without a leaf shutter.

The implosion of the leaf-shutter business accelerated in the 1960s and 70s. The 1970s were a tumultuous period for Carl Zeiss and its photo-related businesses. The failure of Zeiss Ikon and the sale of Voigtländer to Rollei reshaped the Zeiss enterprise. (Rollei later moved much of the ex-Zeiss/Voigtländer production to Singapore in the early 1970s to “compete” in the emerging far-eastern-dominated photographic industry. Rollei filed for bankruptcy in 1981.)

A business decision was made to eliminate redundant businesses, and the Deckel business was spun off in a public offering in the early 1980s as a tool-manufacturing company. The Prontor business was redesigned by Zeiss to be a key mechanical products manufactory both for Zeiss and for other equipment

manufacturers. New projects and leveraging the mechanical manufacturing capabilities would be the new business (together with a small shutter business, which continues today).

### Shutter design and development

At the beginning of the twentieth century, although shutters were certainly being produced in France, Germany, Great Britain and the United States, most of them were designed for studio use and were not small enough to meet the growing demand for “miniature” shutters that could be folded up into the case of a bellows-type camera. The Gauthier brothers understood this dilemma and soon produced a truly innovative product, their first offering, under the name “Koilos” in 1904. Several improved versions of the Koilos followed, and in 1908 AGC introduced the “Ibso” shutter. The Ibso was also the first shutter to incorporate the now-common tapered-tip cable release instead of the bulky pneumatic bulb and tube (which had a large piston apparatus on the shutter, visible in the illustration of the 1904 Koilos opposite). That development may seem trivial, but the cable release as we know it today takes up a minimal amount of space as com-

pared to the old bulb and tube device.

This first offering was quickly followed by the Vario, Pronto, Derval, Embezet and the EO shutters. These new shutters met the needs of the contemporary lens manufacturers, providing standard threaded lens mounts in the three standard sizes designated “00” (double null), “0” (null) and “1.”

Each shutter fit a different niche. Some provided a single cock-and-release mechanism, where the action of the shutter lever first loads the mechanism and then “trips” the shutter in a single movement. Others required cocking the shutter by a separate lever, then pressing a release lever to trip the shutter. Simple yet reliable Vario and Pronto shutters became a standard on mass-marketed low-end cameras for the next 30 years. The simple two-blade shutter with limited speed selection provided enough flexibility for an amateur photographer to produce excellently exposed film.

The higher-end models sported the three-leaf shutter design, which became the emblem of the company for much of the 20th century. In a succession of improvements through the 1920s and 30s AGC delivered technical improvements and features demanded by the hungry camera-manufacturing industry around the world. It became commonplace for fine German shutters to be used in camera manufacturing from Tokyo to New York.

Gauthier designed shutters for even simpler cameras; these were delivered under the names “Acro,” “Perco” and “Singlo,” and had only M, B and T settings.

With the invention of the Ibso, high-end shutters were finally freed of the pneumatic brake (a closed end tube, located at the top of the shutter, as a dampener to prevent “bounce” of the blades as they closed). Even though the invention of the geared brake in the Ibso was registered in 1913, photographic enthusiasts had to wait until after the First World War to own one. To no-one’s surprise, with the cancellation of German patents many firms, worldwide, began producing modern leaf shutters that contained AGC technology.

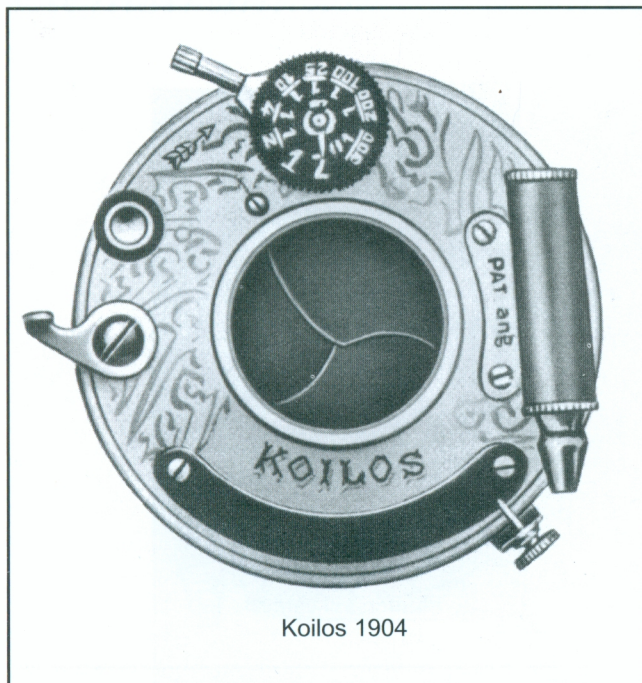

Koilos 1904

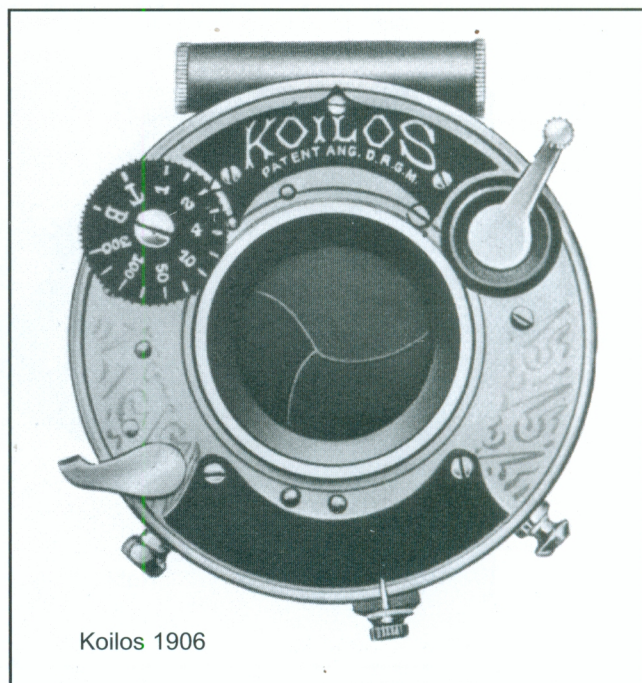

Koilos 1906

The size of the shutter continued to shrink. Miniature cameras appeared in increasing numbers throughout the 1920s. New, updated, Pronto and Ibsor shutters continued as important products for the company. New features continued into the 1930s. Even during the difficult depression years, Gauthier delivered innovations culminating with flash contact by 1939. Old names were retained and updated, and one new name appeared—the “Prontor”—that would change the company.

### Flash and shutters

The Prontor family of products would grow and become the primary source of income for the concern. By 1939 the Prontor II contained the now standard “PC” connection for flash connection. In 1939 there were many standards, but it was to be Gauthier’s PC that would eventually rule.

Wartime saw the end of consumer production. With the loss of prewar manufacturing capabilities, Gauthier started anew in 1946, when small numbers of pre-war shutters were assembled, mostly from prewar parts. Work began on an updated Prontor II, and the Prontor-S was delivered in 1948. It would be another year before the updated Vario and Pronto economy-minded shutters were again offered. All these

shutters had the faster speeds and better regulation that color photography demanded.

Although Gauthier had a flash contact the shutter was not fully synchronized, a feature that the Americans had already delivered. In 1952 the new fully synchronized Prontor-SV once again put Alfred Gauthier on the same footing as the competition.

### Collapse of leaf-shutter photography

Much of the 1950s into the 60s saw a greatly reduced differentiation in leaf-shutter cameras. Zeiss Ikon, Voigtländer, Agfa, Braun, Balda and Eastman Kodak delivered mid- and high-end cameras with Synchro-Compur automatic shutter systems, which produced adequate results for their time. Their medium- and low-priced models frequently sported the Prontor 250S and 500LK shutters with the same lackluster presence. The last of the leaf-shutter SLRs used Prontor-Reflex-P shutters, which were known for their simpler and more reliable design than the Compur equivalents. More recent deliveries have been in the press or larger-format arena with the Prontor Press and Polaroid variations of the same. During the 1990s and into the new century Prontor still produces components and freestanding shutters such as its Pron-

tor-Magnetic E, a specialized electronic shutter for scientific and medical use, and components for motion-picture cameras and the famous Hasselblad.

### Fine mechanical manufacturing

With the general downtrend in the photo business in the 1960s and 70s, Prontor started to move into the medical-device business in 1969. During this period through the 1980s and into the 90s, Hasselblad continued to be an important customer. The manufacture of quality machinist tools, lathes and milling machines went “east” in the 1980s and 90s. Prontor learned to leverage the technical expertise of its development staff to venture into the component-supply business for microscopic mechanical components, and medical technology arenas.

Today’s key competencies include: custom machining, electroplating (chromium, nickel and others), painting and coating, plastic injection molding, prototyping, and building assemblies and components.

By the mid 1990s Prontor achieved the ISO 9001 standard, an international certification that they meet only the highest technical standards. In this century, Prontor has continued to develop their core businesses while maintaining their legacy of manufacturing shutters. □

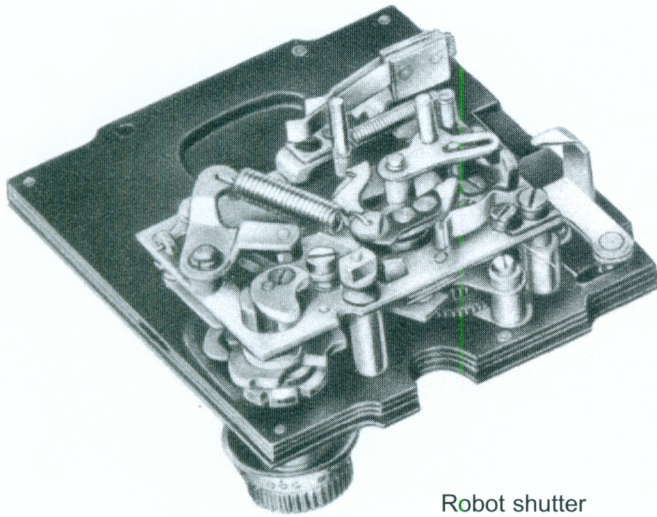

Robot shutter

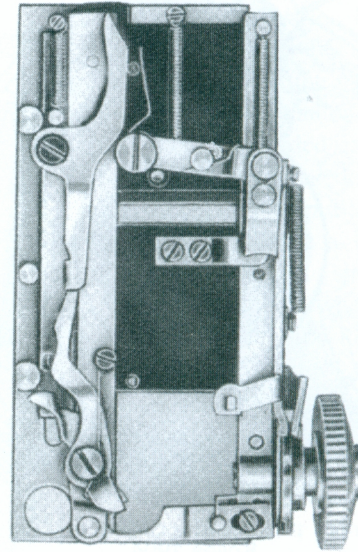

Telma shutter

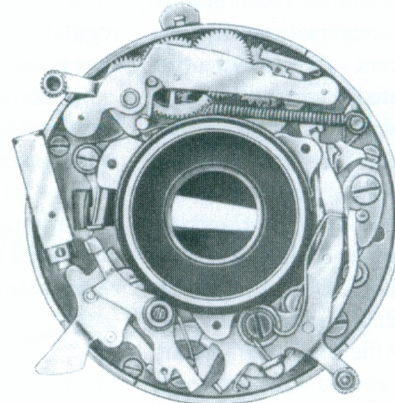

### Alfred Gauthier and Prontor: A Bibliography

- ◆ 50 Jahre Alfred Gauthier GmbH, Maul & Co., Nürnberg, Germany 1952
- ◆ Unpublished spreadsheet provided by Gerd Winter, Prontor, Calmbach, Germany, 2002
- ◆ Materials from the Prontor Werk website: <http://www.prontor-werk.de/> (in German)
- ◆ [http://www.prontor.de/de/home\\_e.nsf/](http://www.prontor.de/de/home_e.nsf/)  
(in English; follow links to "Photography" and "Shutter production")
- ◆ Camera Classics website, Prontor shutter section, at  
<http://home.t-online.de/home/tigin/shutpronto.html> (bilingual, Ger-Eng)
- ◆ "How it was in Calmbach, from 1900 to 1917" by Fritz Barth  
<http://home.t-online.de/home/Mich.Barth/Heimatsforschung/wieeswar.htm> (in German)

*Lichtstrahl.....*

*from Charles Barringer*

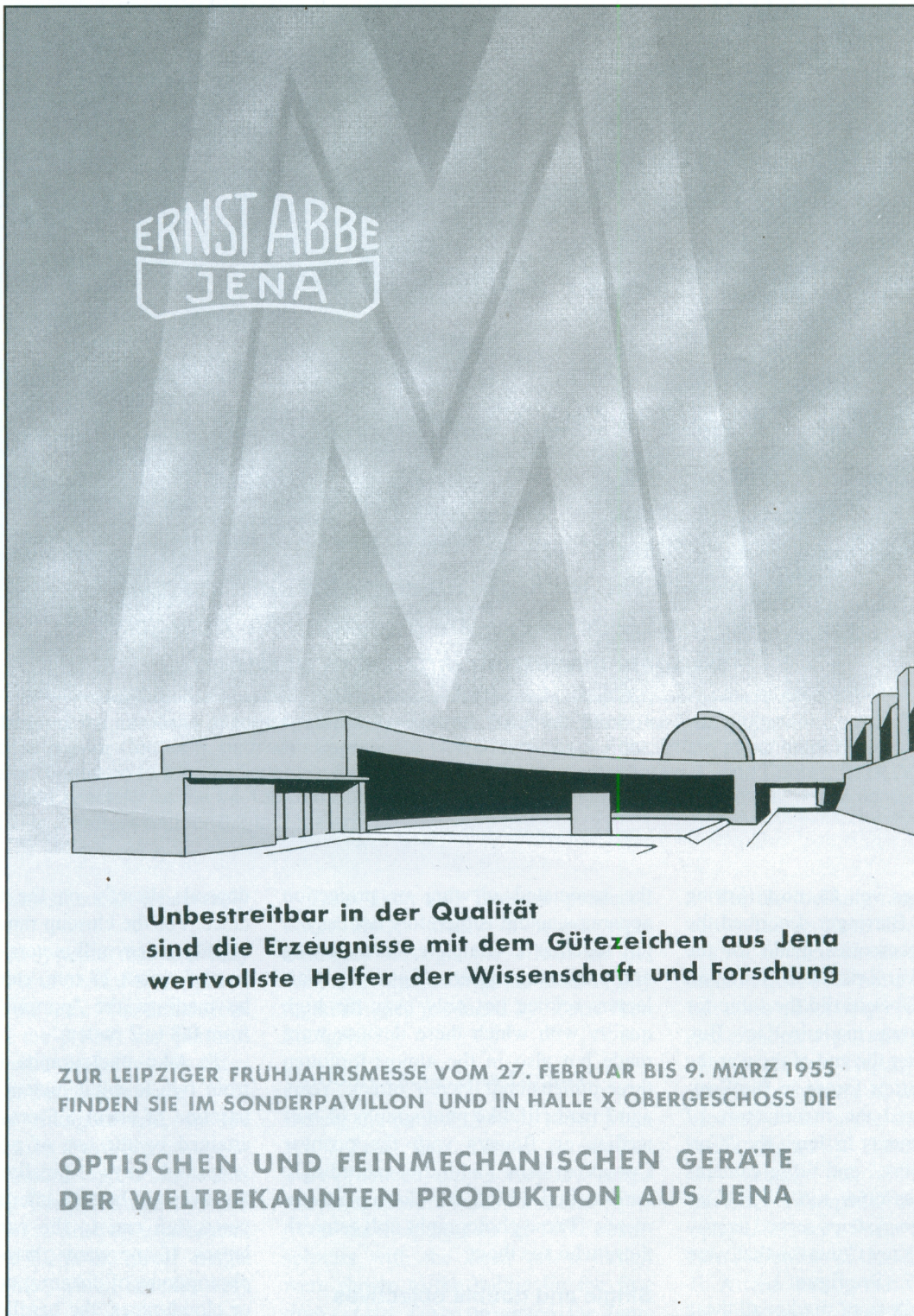

ERNST ABBE  
JENA

**Unbestreitbar in der Qualität  
sind die Erzeugnisse mit dem Gütezeichen aus Jena  
wertvollste Helfer der Wissenschaft und Forschung**

ZUR LEIPZIGER FRÜHJAHRSMESSE VOM 27. FEBRUAR BIS 9. MÄRZ 1955  
FINDEN SIE IM SONDERPAVILLON UND IN HALLE X OBERGESCHOSS DIE

**OPTISCHEN UND FEINMECHANISCHEN GERÄTE  
DER WELTBEKANNTEN PRODUKTION AUS JENA**

This advertisement appeared in a German photographic magazine around the end of 1954 or early 1955, at a time when Carl Zeiss Jena, in the Eastern Zone, was forbidden to use the name "Zeiss." By reference to the co-founder of the original enterprise,

Ernst Abbe, and to Jena, they left no doubt of their heritage. The reverse side of this sheet carries an advertisement from Zeiss Ikon AG, Stuttgart, so the magazine must have been West German.

*Charles Barringer Jr.*

*Matters arising ...*

## Postwar stereo devices from Carl Zeiss Jena

Bernd Otto, Frankfurt, Germany

---

*In the last issue we heard about stereo devices from Zeiss Ikon and Kiev. They were also available from Jena, with some interesting differences in design.*

---

In *Zeiss Historica* vol. 25, no.1 (Spring 2003) Charles Barringer described the stereoscopic accessories made for the pre- and post-War Zeiss Ikon Contaxes, and Pierpaolo Ghisetti did the same for the similar cameras made in Kiev. But, as we know, after the end of the war the Russian occupation forces in the Eastern Zone ordered the manufacture of comparable cameras in Jena, the "Carl Zeiss Jena Contax," and those cameras had stereo accessories too. The Carl Zeiss Jena stereo systems served as prototypes for the Kiev Contaxes that were to come in 1955. (See figure 1.)

In today's collectors' market all these stereo systems command increasing interest and high prices. Many of them, to be sure, can now be found in collectors' show cases. But the interest appears to be mostly directed toward the photograph-taking systems, rather than

the associated viewing or projection apparatus, and it is therefore not easy to put together a complete stereo taking and projecting system (figure 2). Collectors rejoice not only over the high quality with which these devices were made but also in the almost-forgotten three-dimensional stereo effect. Years ago I made lifelike photographs of butterflies on flowers with the postwar Contax system and the exceedingly hard-to-find 13/9/6 cm closeup attachments. These photographs still astonish those who see them.

### Single and double objectives

There are two distinct techniques for stereo photography, as was shown in the articles by Barringer and Ghisetti. One can have either a single objective or two separate objectives a short distance apart. Their separation, or "baseline,"

depends directly on the focusing distance. For the closeup range it amounts to only a few millimeters. For a baseline of about 18 mm, stereo shots can be made at the "portrait" range, say from 0.8 to 2 meters.

To take photographs in the range from two to eight meters one needs a baseline of about 6.5 cm. This can be attained by the use of prisms to converge light-rays originally separated by the average human interpupillary distance, 6.5 cm, to the camera lens or lenses. If one wants three-dimensional photographs of distant mountain ranges or cloudscapes, the baseline separation would have to be more than a kilometer — obviously not possible with a single camera. But two photographers, aiming at the same pre-arranged point in the landscape and coordinating the timing of their exposures by the use of

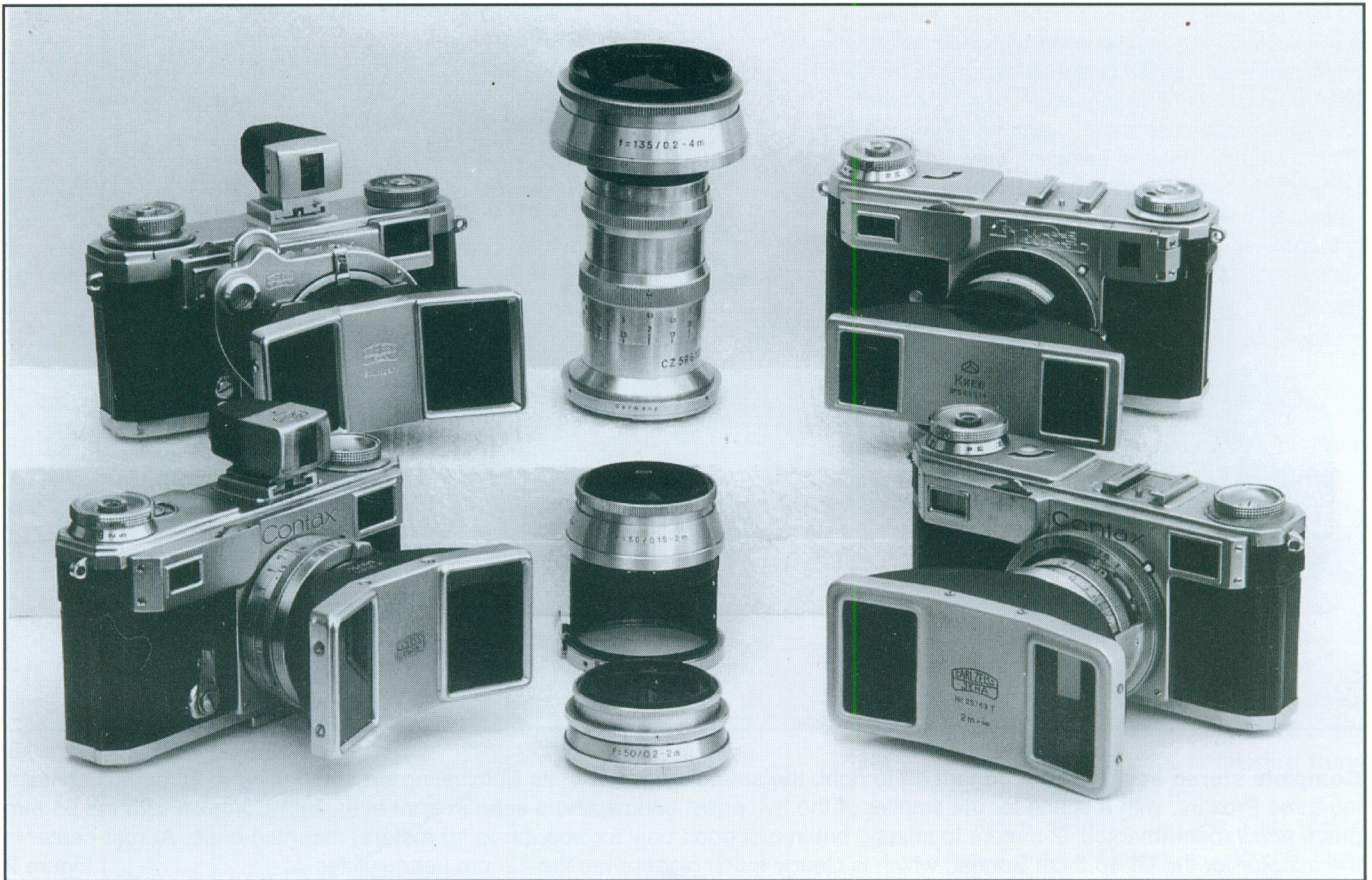

**Stereo attachments for cameras of four systems, compared.** Back left: Stereotar-C on a postwar Contax IIa, and front left: Stereotar-C on a prewar Contax II, both with appropriate viewfinders. Back right: Prism attachment on a Kiev 4A (note the half-frame mask clipped on to the viewfinder window); Front right: Prism attachment on a Jena Contax. Back center: Prototype beamsplitter made specially for the f/4 135 mm Sonnar, to work over a range of 0.2 to 4 meters. Front center: Prism attachments for 0.15 to 2 meters and for 0.2 to 2 meters. Figure 1

mobile telephones, could conceivably do it.

Those stereo systems that have only one objective lens need a beamsplitter placed before the lens. The dimensions and angles of the prisms that perform this function will determine the effective baseline of the combination.

Zeiss Ikon Stuttgart had, in the 1950s, brought out a two-objective system for the Contax and a single-lens system for the Contaflex and Contina. There was also a close-up attachment, working in the 0.2 to 2.5 meter range, for the Contaflex, which is today very hard to find.

In general the preferred method for stereophotography is the two-lens system, but the beamsplitter method with a single objective can also produce excellent photographs with astounding three-dimensional realism.

Zeiss Ikon AG Dresden produced fewer units, many of which were destroyed through the effects of the War, as compared with the more highly regarded ones produced by Zeiss Ikon Stuttgart.

### The Carl Zeiss Jena Contax

During the period 1946 to 1956, when 1,500 Zeiss Jena Contax II cameras were produced, only a very few stereo attachments were made for them.

At the Leipzig Fair in 1950 beamsplitters with the Zeiss prism design were shown to the public for the first time. Carl Zeiss presented the units with a choice of two mounts, the first one for the Carl Zeiss Contax and the other for the new Prism Contax S. One advantage of the beam-splitter principle is that a single attachment can work with different camera systems.

For the focusing range from infinity to two meters Zeiss developed a design with a 65 mm baseline. Naturally the stereo effect does not extend to infinity, but takes effect only between about two and eight meters. At the same time Zeiss showed at this Leipzig Fair a closeup attachment with a 12 mm baseline, for closeup work in the one to two meter range (figure 3). The rare prospectus of this Leipzig Fair shows, with these devices, a "torpedo" viewfinder developed as a stereo-finder and also a quite rare illustration of the Carl Zeiss Contax II. A lens catalog that came out a year later shows a large beamsplitter on a Contax S. Since the Zeiss intention was for these to be used on different kinds of cameras, each with the appropriate adapter, adapters for the Carl Zeiss Jena Contax are found very rarely.

The Jena Contax adapter is based on



**Complete stereo system from Jena.** Left to right: the stereo viewer, with its illuminating system behind it; Fitted box containing three Proxars, with a space for the smaller of the two prism beamsplitters seen in front of it; Jena Contax II with the 65 mm prism attachment (marked "2-meters to infinity" but in fact good only for about 8 to 10 meters) mounted on it. At rear center is the adapter for the f/4 13.5 cm Sonnar, which is clearly much bigger than the 12 mm beamsplitter. Figure 2

the 1937 bayonet-mounted polarization attachment (catalog number 541/27). This is a cylindrical design that surrounds the objective and permits the lens diaphragm to be adjusted through an opening in the side (see figure 4). A lens catalog from February 1951 shows the Zeiss prism attachment as a prototype, or a "null series."

A serial number can be seen on the prism, although serial numbering was later used only on the smaller devices. The 12 mm attachment illustrated in the catalog carries the numbers 25746 and 25749, and the two 65 mm attachments are numbered 25757 T and 25764 T. Thereby we see that the larger device received T-coating, while the closeup attachment did not have T-coating at first. I have seen other examples with the numbers 25763 T for the 65 mm type and 25752 for the 12 mm type. These both derive from a trial series, that is, they are prototypes. There is also a set of stereo prisms for the 13.5 cm Tele-Sonnar, (not offered in the prospectus) that has serial number

25777 and a white-painted "T" rather than the usual red T. This prism attachment is designed for stereophotography in the range 0.2 to 4 meters. The one for the Sonnar f/4 13.5 cm works only over the focusing range above 1.5 m. This device, which looks very much like the normal 12 mm beamsplitter, actually has a different optical design and the angle of its prisms is such that it cannot be used on the shorter focal-length lenses. To focus as close as 0.2 m a closeup attachment would naturally be required. A focusing-screen adapter for focusing closer than 1.5 m would be useful, but these accessories exist only as prototypes and were never put into production.

Zeiss offered three close-up attachments for the 12 mm baseline prisms. These Proxars 50, 30 and 20, catalog number 913, taking 40.5 mm screw-in filters, are appropriate for use in the closeup range down to 0.2 meters. Later, in a model with T coating, the range was extended down to 0.15 m. With a supplementary lens added to the

camera objective the range can be extended further. Both the 12 mm and the 65 mm attachments exist with an opening diameter of 26 mm, suitable only for the Tessar f/3.5 and f/2.8 5 cm lenses. The f/2 5 cm Sonnar, with a 30 mm opening diameter, and the f/1.5 5 cm Sonnar, with a 34 mm opening diameter, I suspect can only be used by stopping down although I have not tried it.

### Viewing and projecting

After taking stereo pairs with either the 12 mm or the 65 mm prism attachments one can view them as slides mounted in the half-frame format, 16 by 23 mm, with a miniature stereo viewer. The viewer was made of bakelite and was fitted with a blue glass for daylight-corrected illumination. After single-lens stereophotography the half-frames need not be separated; one can view them together, uncut. Two rubber eyecups keep out annoying stray light.

For viewing in larger groups Carl Zeiss Jena offered a stereoprojector

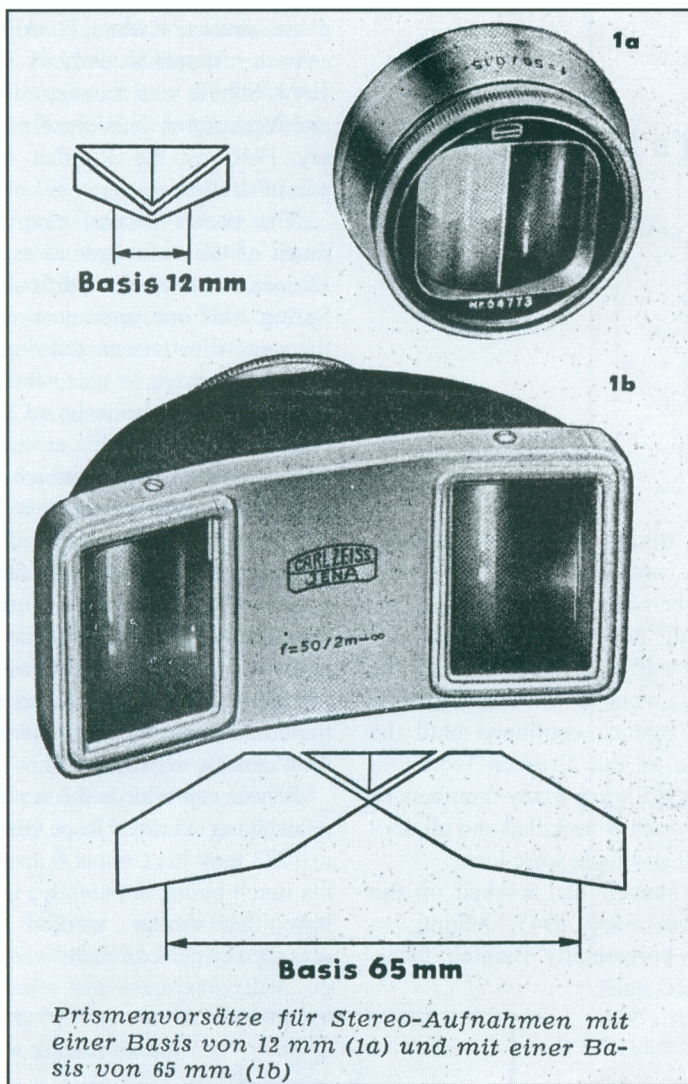

Catalog page from a Leipzig Fair of the mid-1950s, showing the arrangement of prisms in the 12 mm baseline and 65 mm baseline beamsplitters. Note that each attachment has four single prisms. The same two small right-angled prisms are used in each design (although they look different in these differently-scaled drawings) and are provided to avoid overlap of the stereo images such as occurs in the Stuttgart and Kiev designs. Figure 3

ting. For these accessories the Russian engineers proceeded with further development.

The system does not work with auxiliary viewfinders but rather with a half-frame mask clipped to the rangefinder (figure 1). This part was often lost and is missing from the kits found today. It was, incidentally, also provided for the Zeiss Ikon Dresden Stereotars (for the Contax II and III) but is missing from many of those outfits too.

Stereo systems for the Carl Zeiss Jena Contax, Contax S, Exakta and other systems were listed in many catalogs between 1952 and 1966 and certainly manufactured and sold in large numbers. But then, by the middle of the 1960s, interest in three-dimensional photography declined and with it the production of stereo devices ceased. □

with a 750 watt lamp. This extra-bright projector merges the images with a prism-system, after passing through polarizing filters. Projection must be on a metallic screen, and the images viewed through polarized eyeglasses. This projector, with two f/1.6 120 mm lenses, weighs a solid 26 kg.

**Stereo systems for the Kiev**

The Zeiss design evolved in 1955 for the Kiev camera was smaller and therefore cheaper. The entrance aperture was no longer round but rather quadrilateral, bigger than the round entrance aperture of the Jena attachment, and it is therefore possible that it can be used with the lens wide open, although I have not tested that. The integral adapter has two openings that reveal the diaphragm set-



Derivation of the Carl Zeiss Jena Contax adapter (left) from the 1937 polarization attachment, catalogue number 541/27 (center); on the right, a close-up stereo prism attachment. All three have the same lens mount with a cut-out to allow reading and adjusting of the aperture. Figure 4

## Book review

### Contax S: A History of the World's First 35 mm Prism SLR Camera

Alexander Schulz

Published by Lindemanns Verlag, Stuttgart  
ISBN: 3-89506-236-7

Reviewed by John T. Scott

Regular readers of *Zeiss Historica* may remember the article by Alexander Schulz in the Spring 2002 issue entitled "From draft to model: The first steps toward the Contax S." Earlier, in Fall 2001, we had carried another article by Schulz on "The Early SLR Contax of 1949." Those two articles told the story of the development in Dresden of the first single-lens reflex with an erect and laterally correct viewfinder image—that is, with a pentaprism—which became known as the Contax S. (The claim for priority is also made for the Italian Rectaflex, introduced in the same year, 1949, but the Contax patent was submitted first.)

Now we have a full-length book by Alexander Schulz that includes the same material as in the *Zeiss Historica* articles but with much more beside.

Schulz begins in his first chapter with the formation in Dresden of Ihagee, by Johann Steenberg in 1912. After much experience with the 6 × 6 cm Exaktas ("Exactas" in the East), Ihagee brought out the Kine Exakta in 1936, just a year after the introduction of the twin-lens Contaflex by Zeiss Ikon and when production of the rangefinder Contaxes was in full swing. By 1939 Benno Thorsch of Kamera-Werkstätten Dresden had added the Praktiflex, another 35 mm reflex like the Kine Exakta, and sales of these two single-lens reflexes soon threatened those of the Contaflex.

World War II brought production of all three systems to a stop, but the message for Zeiss Ikon was clear; the future

of camera design lay with the single-lens reflex, not with the TLRs. Schulz credits Hubert Nerwin with leading the first hesitant design work on an SLR Contax as early as 1937. During the early 1940s work on the camera, to be called the Syntax, continued until the destruction of the Dresden works in February 1945 when many members of the design team were killed and all documentation and tools were lost.

Schulz himself had worked on the design from May 1943, helping to develop a horizontally running focal-

plane shutter. Although work on the camera resumed as early as September 1945, Schulz was transferred to Kamera Werkstätten Niedersiedlitz in January 1946 by the Russian occupying administration.

The book's second chapter covers much of the same ground as the *Zeiss Historica* articles, particularly the Spring 2002 one, and contains many of the same illustrations and much verbatim text. It takes us up to the introduction of the newly designed SLR, now called the Contax S, at the Leipzig Spring Fair of 1949—which is where the third chapter begins. It is in this third chapter that a sectioned drawing, in an isometric view, of the camera first appears. I counted three more appearances of essentially the same drawing, with very slight modifications but from the identical viewpoint, in later parts of the book where the various versions of the Pentacon are discussed.

Schulz reproduces the results of the painstaking work of Rick Oleson, who in 1983 took his Contax S apart (during his lunch hours, apparently) to find out how the shutter worked. Oleson's accompanying text reads very like the

**Sectioned drawing of a Pentacon with the Ernemann Tower logo.** This same drawing, with minor variations as necessary, was used for the Contax S and various versions of the Pentacon over several years.  
(Reproduced from *Contax S*, by Alexander Schulz.)

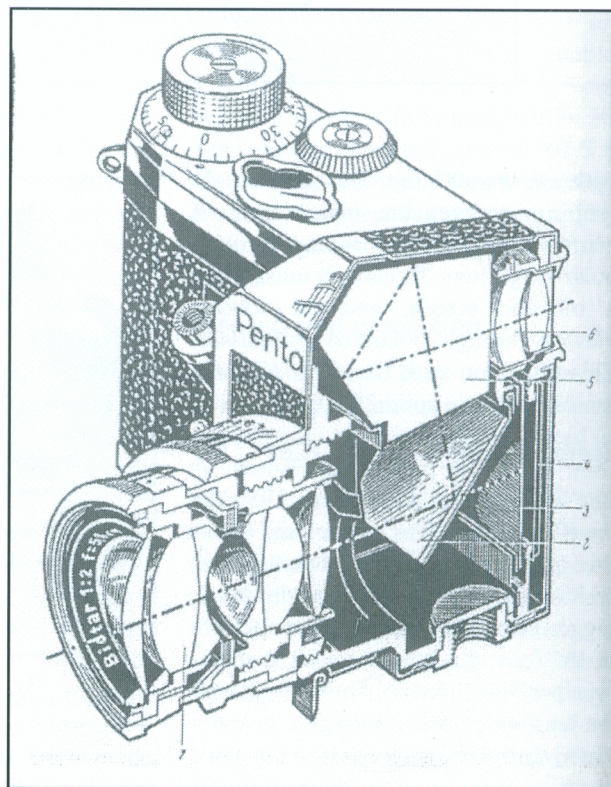

work of Heath Robinson (for British readers) or Rube Goldberg (for Americans) as he explains how the shutter is supposed to work. Here is a flavor of it:

*“Winding sequence: As knob 1 is wound clockwise, it drives main timing gear 2, also clockwise. Timing cam assembly 13/14 cannot rotate because it is held in position by the shutter release; therefore, rotation of gear 2 causes tensioning of timing spring 4. As gear 2 rotates, it winds shutter via gear 3; once shutter is fully wound, cutout section in gear 2 releases gear 3 which would then reverse except for pawls 15/16 which prevent rotation of the shaft. Gear 2 also drives film sprocket, transporting film to next frame. As shutter spool rotates, a pawl at its lower end causes a pulley 7 to draw mirror 8 down via a cord. Once fully wound, the pawl disengages, the pulley reverses under spring force, and the cord goes slack. Mirror is now held in place by a pawl linked to the shutter release.....”*

There follows an even longer description of the discharge sequence. It is perhaps not surprising that, as Schulz puts it, “the shutter was highly susceptible to malfunction.”

Indeed, in a detailed discussion of the importation of Contax S cameras into the US by the Ercona Camera Corporation in 1949 and after, he writes “Unfortunately, at the outset, about 50 per cent of these cameras arrived with defective shutters...” Here, and elsewhere in the description of Ercona, Schulz is quoting Nicholas Grossman, who got the information from Charles Frank, co-owner of Ercona. These pages of Schulz’s book are illustrated with a small reproduction of an advertisement by Ercona for the Contax S. Fortunately ZHS member Joe Brown of San Antonio, Texas, has provided an original of that advertisement, which I show at full size on the page following this review.

The next chapter, “Hostile Brothers,” begins with a brief survey of the disputes between Eastern and Western Zone branches of the Zeiss companies,

and the legal struggles over trademarks. The story then continues with the change of the camera name to “Contax D” (possibly D for Dresden?), the arrival of, first, the “Ernemann Tower” logo in place of the Zeiss Ikon achromat, and then, by October 1952, the new “Pentacon” trade mark. Schulz shows illustrations of five variations of the camera with the Pentacon name, and five with special names (“fantasy names”) for the American market. Then came the Contax E and the Pentacon E (the latter for export to the West), cameras with a built-in exposure meter.

By 1956 or '57 development and production were transferred to VEB Kamera Werk Niedersedlitz, where the Contax/Pentacon F appeared with continuing improvements and modifications until March 1962. Its ghost lived on briefly in the People’s Republic of

China, in a few prototypes called the “Heavenly Pond.” This Chinese copy never made it into production.

The book closes with brief surveys of the Praktica series of cameras from East Germany, and lenses and other accessories for all these cameras from the Contax S onwards.

Despite the help with editing that Schulz credits in his Preface, there are still some of the errors that are seemingly unavoidable in a translated work. For example, the words “...and blind know instead of self timer” on page 51 are meaningless until you guess that they are about a blind knob. And on page 56, “However, no rule cannot be made that does not have exceptions” appears to have too many negatives. But all in all, this book is a thorough, well-produced survey of a very interesting period in camera design. □

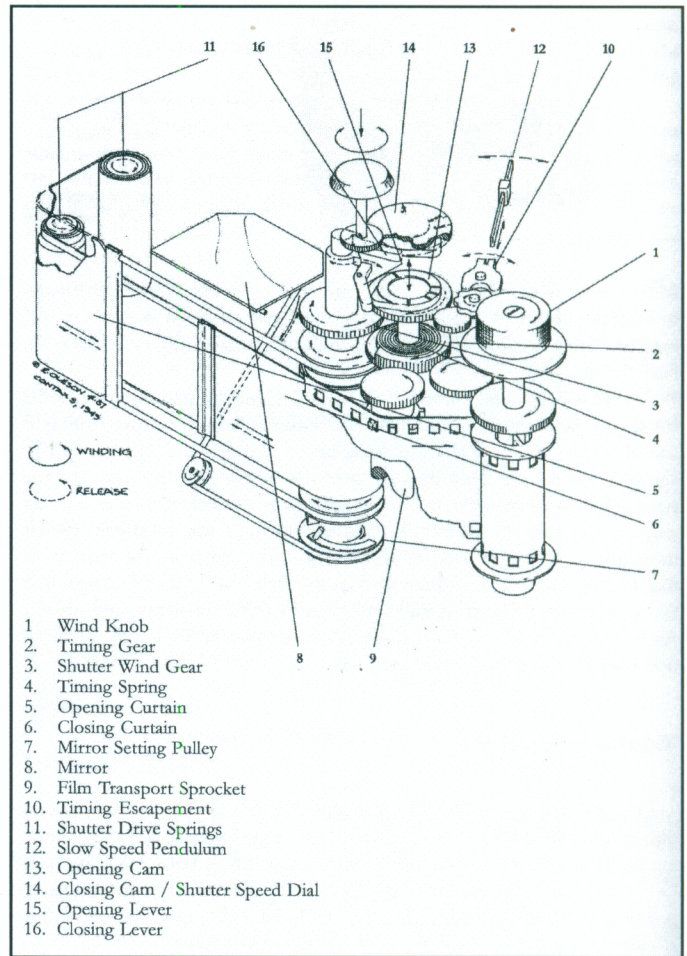

**Rick Oleson’s sketch of the Contax S shutter mechanism, made during two weeks’ of lunch hours. (Reproduced from Contax S, by Alexander Schulz.)**

*Lichtstrahlen.... from Joseph K. Brown*

**NOW** — A Revolutionary **NEW** Contax by 



THE  
**CONTAX-**  
**S**



**First EYE-LEVEL Automatic Reflex Camera!**

Zeiss-Ikon opens a new era in 35 millimeter photography with the introduction of the Contax-S. Gone is the twin-image coupled rangefinder. In its place is a single viewer — the Prisma-Scope — which enables you to sight directly through the camera lens. It yields a life-size, upright image that focuses with the precision of a studio camera! Now, for the first time in a single lens reflex, all focusing and viewing takes place at direct eye level! Without sacrificing the compact qualities of the miniature, the nuisance of parallax is forever eliminated... accessory lenses require no coupling with special and costly rangefinders... close-up photography requires only the addition of extension tubes. Here is the most versatile camera ever created!

Made in the original plant of the Zeiss camera works, the Contax-S bears the stamp of the world's greatest camera craftsmen. Because it can never be mass produced, the Contax-S will be available only in limited quantities. See it now, at your better camera dealer!

with "T" coated  
F/2 Zeiss Biotar Lens  
**\$475<sup>00</sup>**  
Fed. Tax Included  
Fair Traded

The **CONTAX-S**  
**Prisma-Scope**

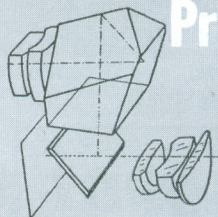

By means of a precision Zeiss lens and ingenious prism arrangement—product of 15 years of research — an always-upright, life-size image is transmitted to the eye of the viewer.

- Parallax is entirely eliminated. No special rangefinders ever needed. What you see, you get!
- Focusing sets new standards in speed and precision.
- Direct visual control of depth of field now becomes a reality for the miniature camera user.
- Close-up photography and copy work require only the addition of extension tubes. Ideal for scientific work.



**All These New Features**

- Built-in flash synchronizer concealed in tripod socket.
- All shutter speeds — *fast and slow* — from a single control. 1 second to 1/1000th.
- Fully automatic! Single knob transports film, winds shutter, and moves exposure counter. Prevents double exposures.
- Equipped with "T" coated Zeiss Biotar F/2 lens (equivalent to T/2) in a universal mount; a full line of accessory lenses and filters available.

*Would you like to own the Contax-S? Write for name of your nearest dealer. Illustrated Brochure "C" on the Contax-S sent free on request.*

**ERCONA CAMERA CORPORATION**

527 Fifth Avenue, New York 17, N. Y.

An advertisement by the Ercona Corporation that appeared in 1950, announcing the introduction to the US of the new Contax S. See the book review on the preceding pages for a discussion of Alexander Schulz's book on the Contax S. (This reproduction from an original supplied by Joseph K. Brown of San Antonio, Texas.)

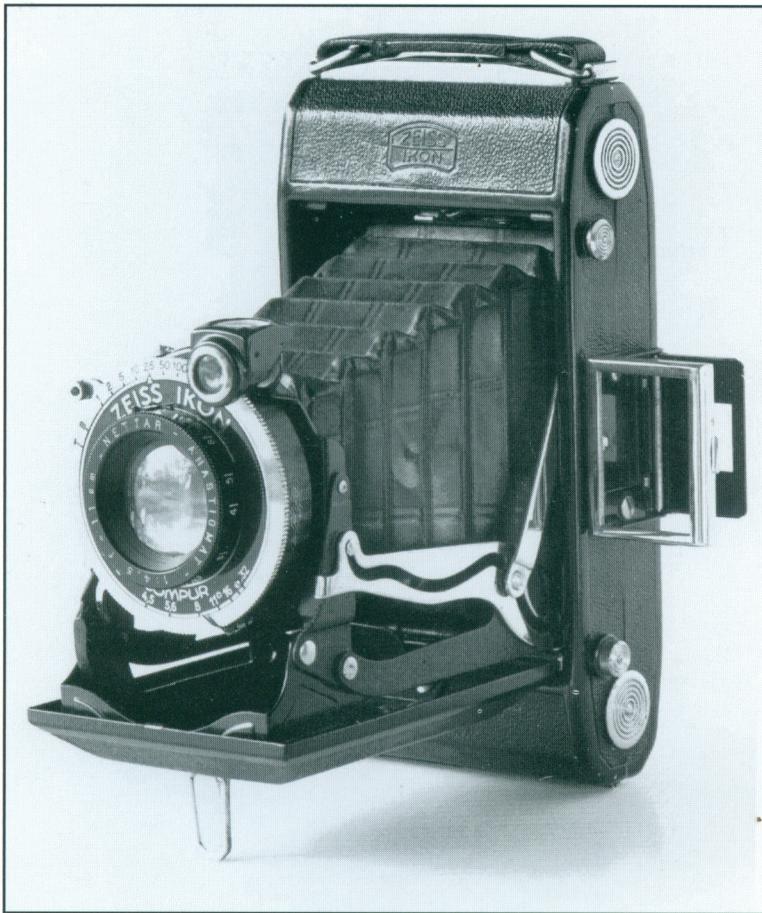

**Joe Brown writes:**

- ◀ **My resistance is very low** when it comes to intact “black-and-nickel” cameras. For example, here (left) is a 6 × 9 Nettar f/4.5, a late one judging from the lens-doublet trademark embossed in the leather covering. It was a sight-unseen trade that attracted me when I heard that it has the big Compur 0 shutter, most of which are remarkably still working.
- ▼ **Below** is a group of some of my other black-and-nickel gang. As well as the Contax I, the Super Ikonta, and the Rollei, there is at the front a type-119 Retina and, on the right, another Kodak, a Duo 620 that I found in near-mint condition.

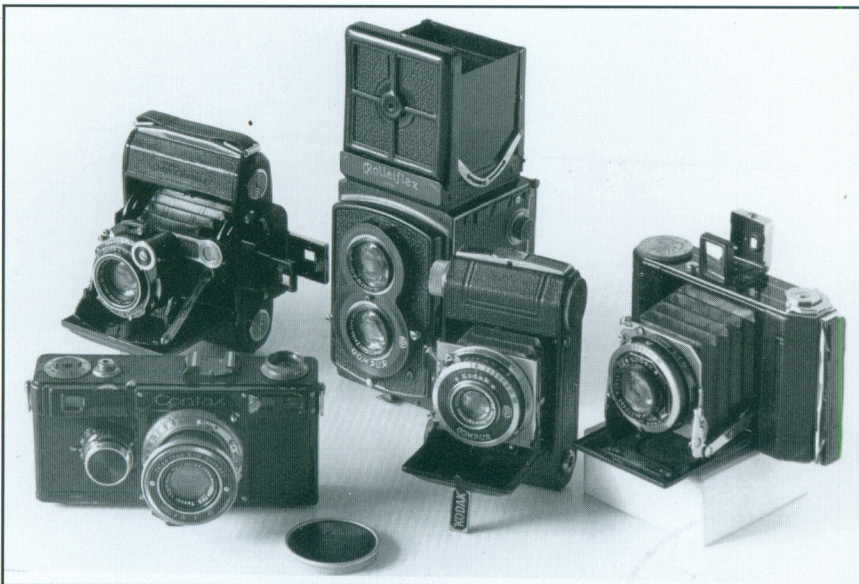

**Back cover:** Two views of a 4 × 14 Feldstecher Luxus from the collection of Fred Schwartzman. It is finished in lizard-skin leather with nickel-plated hinges and lug straps, and brushed-aluminum prism covers. For more on Feldstechers, see the article by Fred Kelly starting on page 2.

